

SANUPS

A11H

Uninterruptible Power Supply

1kVA

100V Model

Instruction Manual

Introduction

Thank you for choosing the SANUPS (A11H).

SAVE THESE INSTRUCTIONS

This manual contains important instructions for A11H that should be followed during installation and maintenance of the UPS and batteries to protect the safety of the service technician* and the customers. To use the UPS correctly and safely, read this manual before using the UPS. After reading, please keep it handy for convenient reference.

This UPS is intended for installation in a temperature-controlled indoor environment free of conductive contaminants.

- Operating temperature: 0 to 40 ° C (32 to 104 ° F)

UPS is an abbreviation for Uninterruptible Power Supply.

Table of contents

§1. Before Use	1
§2. Safety Precautions	2
§3. For Proper Operation	6
§3.1 UPS Input Power Supply	6
§3.2 Installation Precautions	6
§3.3 Usage Precautions	6
§4. Checking the Contents of the Package	7
§5. External Dimensions and Part Names	8
§5.1 Front and Back Panels of UPS	8
§5.2 Control Panel and Indicators	9
§5.3 External Interfaces	10
§6. Installation	14
§6.1 Installation Environment Check	14
§6.2 Installation Space Check	14
§6.3 Installation	15
§7. Wiring	16
§7.1 Battery Connector Connection	16
§7.2 Connecting Optional Equipment	17
§7.3 Input Plug Connection	18
§8. Procedure Until Load Device Operation	19
§9. Preparation Before Operation	20
§9.1 User Setting Check	20
§9.2 UPS Charge	21
§9.3 Outage Simulation Test	22
§10. Load Devices Connection	24
§11. Operating Procedures	25
§11.1 UPS Startup	25
§11.2 UPS Shutdown (Daily)	27
§11.3 UPS Shutdown (If Not to Be Used for More Than a Week)	28

* Service technician

This term is used to indicate service technicians from SANYO DENKI or entrusted from SANYO DENKI with knowledge of this UPS.

Maintenance work must not be performed by other than a qualified service technician.

§12. User Settings.....	29
§12.1 Prior to Modifying the User Settings.....	29
§12.2 Setup Menu List.....	30
§13. Maintenance.....	32
§13.1 Routine Checks.....	33
§13.2 Battery Test.....	34
§13.3 Bypass Breaker Reset.....	35
§13.4 Maintenance by Service Personnel.....	36
§13.4.1 Battery Replacement.....	36
§14. Alarm Sounds.....	38
§15. Troubleshooting.....	39
§16. How to Use Power Management Software.....	41
§17. Using Standard OS UPS Services.....	43
§17.1 Windows NT.....	43
§17.2 Windows 2000/XP/Server 2003.....	44
§18. Using Optional Equipment.....	46
§18.1 Remote Switch.....	47
§18.2 Linked Operation Cable.....	48
§18.2.1 Wiring and Settings for Linked Operation.....	49
§18.2.2 Linked Operation ON Procedure.....	50
§18.2.3 Linked Operation OFF Procedure.....	50
§18.2.4 Linked Operation System Configuration.....	51
§18.3 Outlet Box.....	52
§18.3.1 Outlet Box Wiring and Settings.....	53
§18.3.2 Configuration of an Output line Control System.....	54
§18.4 Combining a Remote Switch and Outlet Boxes.....	55
§18.5 LAN Interface Card.....	56
§18.6 Contact Interface Card.....	57
§18.7 Connecting the Emergency Power Off (EPO) Terminals.....	58
§19. Characteristic of UPS.....	59
§19.1 Basic Operation.....	59
§19.2 Protective Functions.....	59
§19.3 Protective Function Table.....	60
§19.4 Specifications.....	61
§20. Warranty.....	62

§1. Before Use

The procedures to use the UPS are shown in the following. Be sure to proceed as follows to use the UPS safely and properly.

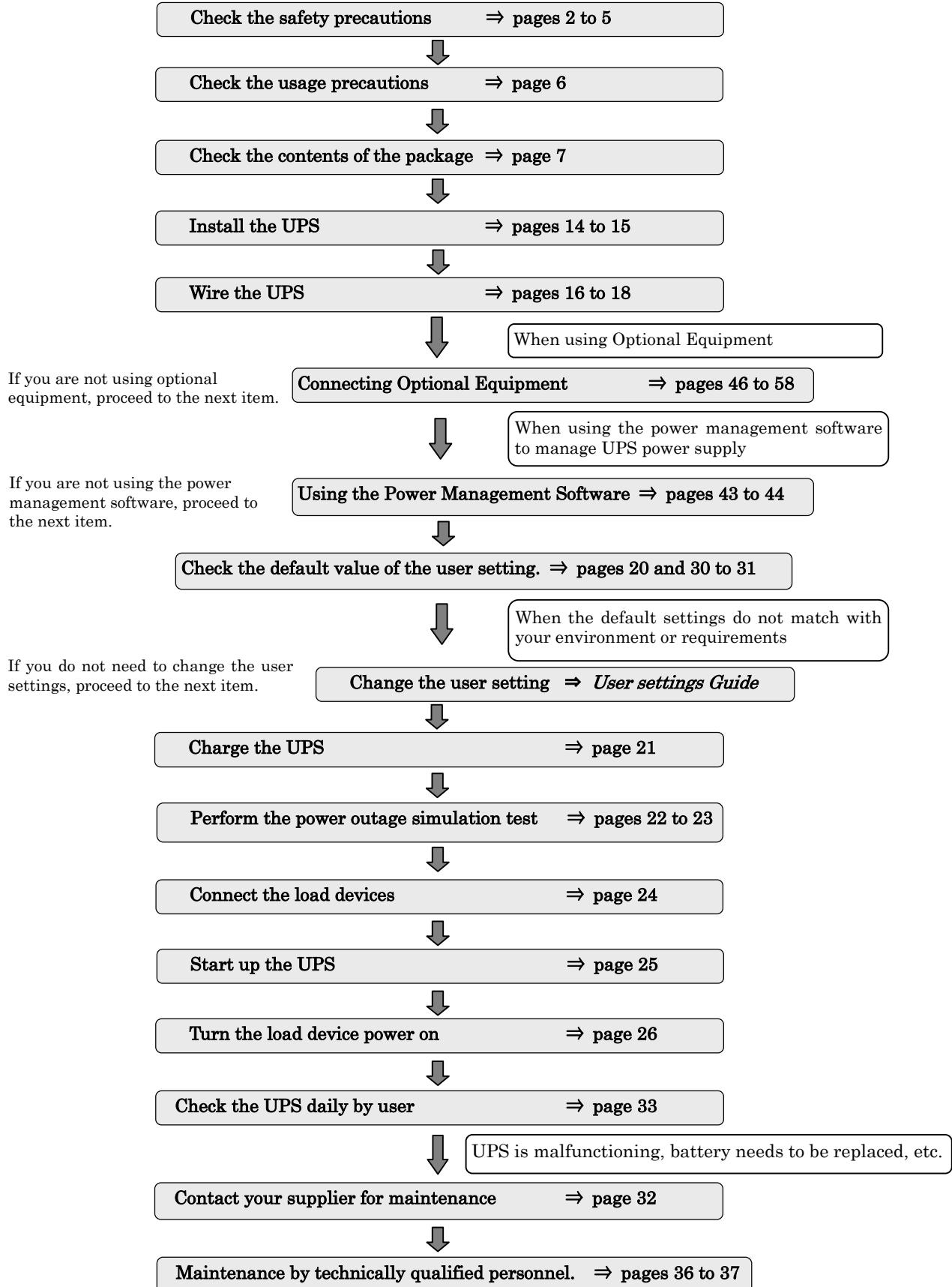



§2. Safety Precautions

PRECAUTIONS (IMPORTANT SAFETY INSTRUCTIONS)

This Manual contains important instructions for operating and maintaining the A11H102U011 and the batteries to protect the safety of the service technician and the customers.





Before installing, operating, performing maintenance or inspecting the UPS, be sure to read this manual and accompanying documents carefully to obtain a clear understanding of the information related to its operation, safety and important precautions.

This manual described two warning levels, DANGER and CAUTION, as described below.

Label	Explanation
 DANGER	Denotes immediate hazards which WILL probably cause severe bodily injury or death, as a result incorrect operation.
 CAUTION	Denotes hazards which COULD cause bodily injury and product or property damage, as a result incorrect operation.

Additionally, even those hazards denoted by  **CAUTION** could lead to a serious accident, so the instructions should be strictly followed.

The following labels indicate particularly important instructions which must be carefully followed. The graphic symbols indicate prohibited and mandatory actions.

Symbol	Explanation
	Indicates actions that must not be allowed to occur (prohibited actions).
	Indicates actions that must be taken (mandatory actions).  : This example signifies that the equipment must be securely grounded.
	Indicates CAUTION (including WARNING). Specific information appears within the graphic symbol or in an explanation nearby.

1. Relocation and Transportation Precautions





CAUTION

- Be careful to avoid falling or dropping the UPS during relocation or transportation, as bodily injury could result.
- Be careful to avoid back strain when handling the UPS.
- To avoid bodily injury caused by dropping the UPS, do not tilt it more than 10 degrees to either side when moving the UPS vertically. Take preventative measures to avoid dropping the UPS if it must be tilted more than 10 degrees when moving it.

2. Installation Precautions







CAUTION

- The UPS should be installed only by technically qualified personnel. Improper installation can result in electric shock, bodily injury, and/ or fire. 
- Never operate or store the UPS in the following environmental conditions. Doing so may cause the UPS to malfunction, sustain damage or deteriorate, which could result in a fire. 
 - In ambient environmental conditions other than those specified in the product brochure and instruction manual (temperature 0 to 40°C (32 to 104° F), relative humidity 20 to 90%), such as in extremely high or low temperature and high humidity.
 - Where the UPS is exposed to direct sunlight.
 - Where the UPS is directly exposed to the heat from a heat source, such as a stove.
 - Where the UPS may be subject to vibration or physical shock.
 - Near a device that may emit sparks.
 - In the presence of dust, salt or corrosive or flammable gas.
 - Outdoors
- Be careful not to block the air intake and exhaust vents of the UPS. Keep the front and back of the UPS at least 20 cm away from the wall. Be careful not to block the air intake and exhaust vents of the UPS. If the air intake or exhaust vent is blocked, the internal temperature of the UPS rises, which could cause battery deterioration resulting in a fire. For maintenance, the UPS requires at least 1 m (39.4 inches) space at the front and 50 cm (20 inches) at the back.
- The space around the UPS must be ventilated. Unless the ventilation airflow is maintained, gas produced by battery charging could result in rupture or explosion of the case. 
- Install the UPS on a stable surface capable of bearing the weight (17kg, 37.48 lbs) of the UPS in the correct manner specified in this manual. If the UPS is installed incorrectly, impact or vibration could cause it to fall or move inadvertently, resulting in bodily injury. Be careful to avoid back strain.
- Move packaging such as plastic bags and film and accessories such as screws to a place that is out of reach of children. If a child, for example, places film over his or her head or swallows a screw, there is a danger of suffocation.

3. Wiring Precautions



CAUTION

- Wiring should be performed only by technically qualified personnel. Incorrect wiring can result in electric shock and/or fire. 
- Protection in primary circuits against over currents, short circuits and earth faults is not provided inside this UPS. Protection in primary circuit against over currents short circuits and earth faults shall be provided as part of the building installation. 
- Connect the grounding cable securely in the manner specified. Failure to connect the grounding cable may result in electric shock. 
- The grounding cables of all load devices* connected to the output of the UPS must be securely connected to the grounding terminal. Failure to connect the grounding cables correctly may result in electric shock. 

* Load devices are devices such as computers that are connected to the UPS.

4. Operating Precautions



DANGER

- Immediately shut the UPS off if it malfunctions, or if an unusual odor or noise is observed. Failure to do so may result in a fire.
- To avoid electric shock, do not open the cover of the UPS. Do not detach the cover of the options, except when you use some options. There is danger of electric shock and equipment damage.



PROHIBITED

- Never use the UPS for the following types of loads:
 - a. Medical instruments used for life support.
 - b. Control units for trains or elevators, failure of which could cause bodily injury.
 - c. Computer systems upon which social or public infrastructure depends.
 - d. Devices which serve applications related to the above.



Contact your sales representative if you need to use the UPS in an application like the above. Special equipment, such as redundant devices or an emergency generator must be incorporated when operating, maintaining and controlling systems in which a UPS is used with loads affecting life-support or public infrastructure-dependent applications.

- Do not smoke or use an open flame near the UPS, as it could cause the UPS to explode or rupture, resulting in injury or fire.
- Do not place containers of liquid, such as a flower vase, on the UPS. If the container was to spill, the liquid could cause a short circuit, resulting in sparks or fire inside the UPS.
- Do not sit, step or lean on the UPS, as bodily injury could result if the UPS was to fall.
- Do not operate the switches with wet hands. There is danger of electric shock.
- All repairs and modifications to the UPS are prohibited. The UPS contains high voltage and no user serviceable parts. Opening the cover, exchanging the battery, parts exchange, and repair can result in electric shock and damage to the UPS when performed by anyone other than qualified service personnel. All such repairs and modifications will void the warranty.



CAUTION

- The following table shows the UPS states resulting from operation of the **MAIN SW** and **ON/OFF** switches. Check the indicators before and after operating. Do not touch the **MAIN SW** and **ON/OFF** switches unless necessary. If power is supplied incorrectly, an electric shock or bodily injury could result.

UPS Status		Power Output Status	LEDs
MAIN SW	ON/OFF	OUTPUT	
OFF	STAND BY	Stopped	BACK UP (off-orange), OUTPUT (off-green)
ON	STAND BY	Stopped	BACK UP (off-orange), OUTPUT (off-green)
OFF	ON	Power supplied from inverter	BACK UP (lit-orange), OUTPUT (lit-green)
ON	ON	Power supplied from inverter	BACK UP (off-orange), OUTPUT (lit-green)

- Avoid inserting sharp objects or fingers into the fan. Doing so may result in bodily injury.
- Do not touch the UPS, including the cables, if you hear thunder nearby. There is danger of electric shock from a lightning strike.



5. Maintenance and Inspection Precautions



CAUTION

- Maintenance and repair of the inside of the UPS should be performed only by technically qualified personnel. Electric shock, bodily injury and burns, fuming, or fire could otherwise result.
- Contact your nearest sales representative or authorized service center to have the UPS checked out or to replace defective parts. Opening the cover carelessly can result in an electric shock or burn.
- Replace the batteries periodically (once every 4.5 years when operated at 25°C (77° F)). Using batteries after their service life has expired may cause a fire.
- Never use organic chemicals such as gasoline, thinner, benzene or detergent to clean batteries. These can cause the casing to crack and leak, resulting in fire.
- Do not allow sharp metallic objects or fingers to touch the battery connectors of the UPS. Doing so may result in an electric shock.
- Do not touch any parts inside the UPS, even when AC input is removed. Voltage produced from the batteries can still cause an electric shock.



6. Radio Frequency Interference



CAUTION

- This equipment has been tested and found to comply with the limits for a Class A digital device, pursuant to part 15 of the FCC Rules. These limits are designed to provide reasonable protection against harmful interference when the equipment is operated in a commercial environment. This equipment generates, uses, and can radiate radio frequency energy and if not installed and used in accordance with the instruction manual, may cause harmful interference to radio communications. Operation of this equipment in the residential area is likely to cause harmful interference in which case the user will be required to correct the interference at his own expense.

7. Battery Handling Precautions



CAUTION

- Battery servicing should be performed by technically qualified personnel. Keep unqualified personnel away from batteries.
- Replace batteries only with the same model and brand: HRL1234WF2FR manufactured by CSB BATTERY Co., LTD. Risk of explosion if battery is replaced by an incorrect type.
- The batteries in this product are lead type batteries which are a reusable resource. Please cooperate by recycling when replacing or disposing of used batteries. Dispose of used batteries according to the instructions. Customers should not dispose of used batteries themselves. To dispose of used batteries, contact your nearest sales representative, an authorized industrial waste handling company, or repack them in their original cartons and send them to your supplier or SANYO DENKI.
- Do not use batteries after their service life has expired. Doing so may result in fuming or fire. Additionally, the battery backup function may fail to operate with such batteries, so that power will not be supplied to the load when a power outage occurs.
- Batteries pose hazards for electrical shock and dangerous short-circuit current. The following precautions should be observed when working with batteries.
 - a. Remove watches, rings and other metal objects.
 - b. Use insulated tools.
 - c. Wear rubber gloves and boots.
 - d. Do not lay tools or metal parts on top of batteries.
 - e. Disconnect the charging source prior to connecting or disconnecting battery terminals.
 - f. Determine whether the batteries have been inadvertently grounded, and if so, remove the source of grounding. Contact with any part of a grounded battery can result in electric shock.
- Do not attempt to open or disassemble batteries. The electrolyte is harmful to the skin and eyes. The battery contains diluted sulfuric acid, which is extremely toxic. If a battery leaks, take appropriate measures to prevent any battery fluid contacting your skin or clothing. Diluted sulfuric acid may cause blindness if it gets into the eye, may burn skin upon contact. It is electrically conductive and corrosive. Observe the following procedures if electrolyte spills:
 - a. Wear full eye protection and protective clothing.
 - b. If sulfuric acid contacts the skin, wash it off immediately with water.
 - c. If sulfuric acid contacts the eyes, flush thoroughly and immediately with water, and seek medical attention.
 - d. Spilled sulfuric acid should be washed down with a suitable acid-neutralizing agent, such as a solution of approximately one pound (500 grams) bicarbonate of soda in one gallon (4 liters) of water. The bicarbonate of soda solution should be applied until evidence of reaction (foaming) has ceased. The resulting liquid should be flushed with water and the area dried.
- Lead acid batteries can present a risk of fire due to generation of hydrogen gas. The following procedures should always be followed:
 - a. DO NOT SMOKE when near batteries.
 - b. DO NOT allow flames or sparks near batteries.
 - c. Before working with batteries, discharge static electricity from the body by first touching a grounded metal surface before touching the batteries.
- If a fire occurs near a battery, do not use water to extinguish it. Use only a powder-distinguishing agent (ABC). Using water can cause the fire to spread.
- Do not dispose of batteries in fire, as they could explode.
- Strictly observe the following precautions when handling the batteries. Failure to do so may cause battery leakage, overheating or explosion.
 - a. Do not solder to any part of the battery directly.
 - b. Do not charge the battery with reversed positive (+) and negative (-) terminal polarity.
 - c. Do not mix different battery types, brands or versions.
 - d. Do not attempt to peel off or break the outer covering of a battery.
 - e. Do not subject batteries to strong physical shock, or throw them away.
 - f. Clean batteries with water-moistened cloth squeezed hard. Do not use organic compounds such as gasoline, thinner, benzene or detergent.
 - g. Electrical energy may remain in a battery even after its service life has expired. Do not allow sparks near used batteries, and protect them from short-circuiting.



§3. For Proper Operation

§3.1 UPS Input Power Supply

This UPS device is designed for a 120 V AC power supply.
Connect the UPS to one dedicated outlet with a 15 A current capacity.

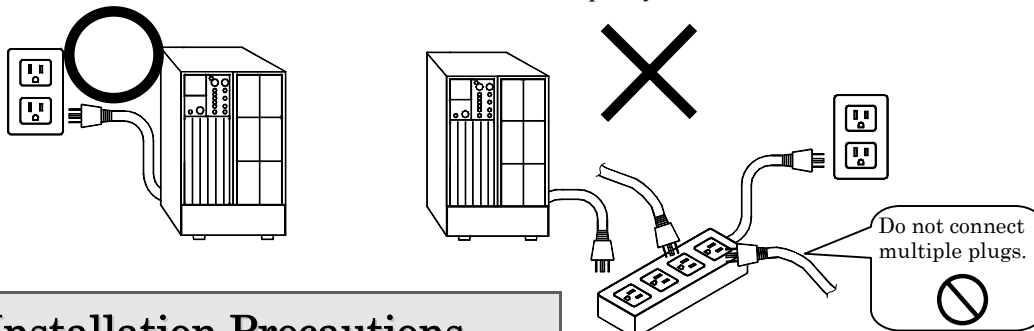

§3.2 Installation Precautions

- (1) Carefully consider the leakage current when a leakage circuit breaker is installed on the input side. The maximum leakage current of the UPS is 3mA.
- (2) Keep the UPS at least 1 m (about 40 inches) away from CRT displays. Other devices which may be sensitive to magnetic flux should be kept away from the UPS, as it emits a slight amount of magnetic flux.
- (3) The UPS employs a fan for forced-air cooling. Provide a clearance specified in §6.2 "Installation Space Check" at the front and back of the UPS to permit free airflow at the air intake and exhaust vents.
- (4) When the AC input power is single-wire grounded, always connect the ground phase to the S terminal (phase) side on the UPS.
- (5) As far as possible, do not ground the output (load) side. If you must make a single-wire grounded connection, always connect the ground phase to the V terminal (phase) side on the UPS. (This is to prevent short-circuiting by the ground.)

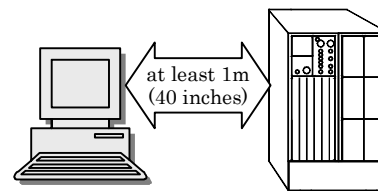

§3.3 Usage Precautions

- (1) Never short-circuit the output terminals.
Doing so causes protective functions to activate or fuses to blow, preventing output.
- (2) Unsuitable load devices
Do not connect laser printers, plain paper fax machines, copy machines, or overhead projectors as load devices. Such devices typically include heating elements that draw high current. This may cause an overload that could prevent battery backup operation when an outage occurs, and could damage the UPS.
- (3) Power supply environment
If the UPS is used in an environment subject to long and frequent power outages (more than once a week), the batteries may not receive sufficient charge, which could result in foreshortened battery life and premature battery failure
- (4) If the UPS is not operated for a long period, the batteries may require recharging. If the batteries in the UPS are left uncharged, their service life will be greatly foreshortened. Recharge (refresh charge) in accordance with the UPS storage environment as shown in the table below.

Storage Temperature	Charge Interval	Operation
25°C	Once every 6 months	At least 20 hours
30°C	Once every 4 months	At least 20 hours
40°C	Once every 2 months	At least 20 hours

Recharging procedures

- ① Set **MAIN SW** on the back panel of the UPS to "ON".
↓ Recharging starts.
- ② Continue operation for at least 20 hours.
- ③ Set **MAIN SW** to "OFF" after at least 20 hours elapses.

- (5) Insulation testing
Before testing indoor wiring insulation, shut down the UPS and disconnect the input and output cables. Conducting an insulation test with the UPS connected may damage electronic components such as the built-in arrester.
- (6) Rack support rails (not supplied) are required to mount the UPS on a rack. For details, contact your supplier or Sanyo Denki representative.

§4. Checking the Contents of the Package

After opening the package carton, check to be sure that it contains all of the following items.

- Are UPS and all accessories in ?
- Is there no visible damage on the UPS?
- Check and put the mark in .

If any item is missing, contact your supplier or SANYO DENKI.

A11H 1

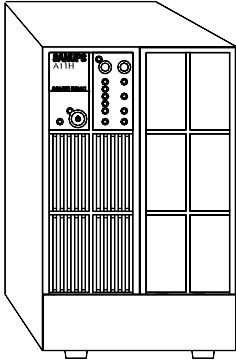

Instruction Manual 1

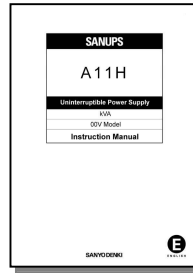

User Settings Guide 1

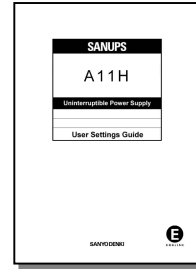

Network cable 1

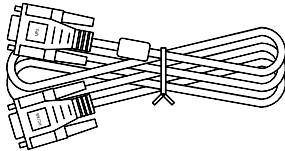

Power Management Software disc CD-ROM 1

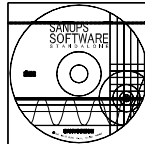

Note about sale or transfer of ownership

If you sell the UPS or transfer ownership to a third party, all accessories and other items supplied with the UPS must be sold or transferred together with the UPS.

§5. External Dimensions and Part Names

§5.1 Front and Back Panels of UPS

Depth: 430 mm (16.93 inches)
Weight: 17 kg (37.5 lbs)

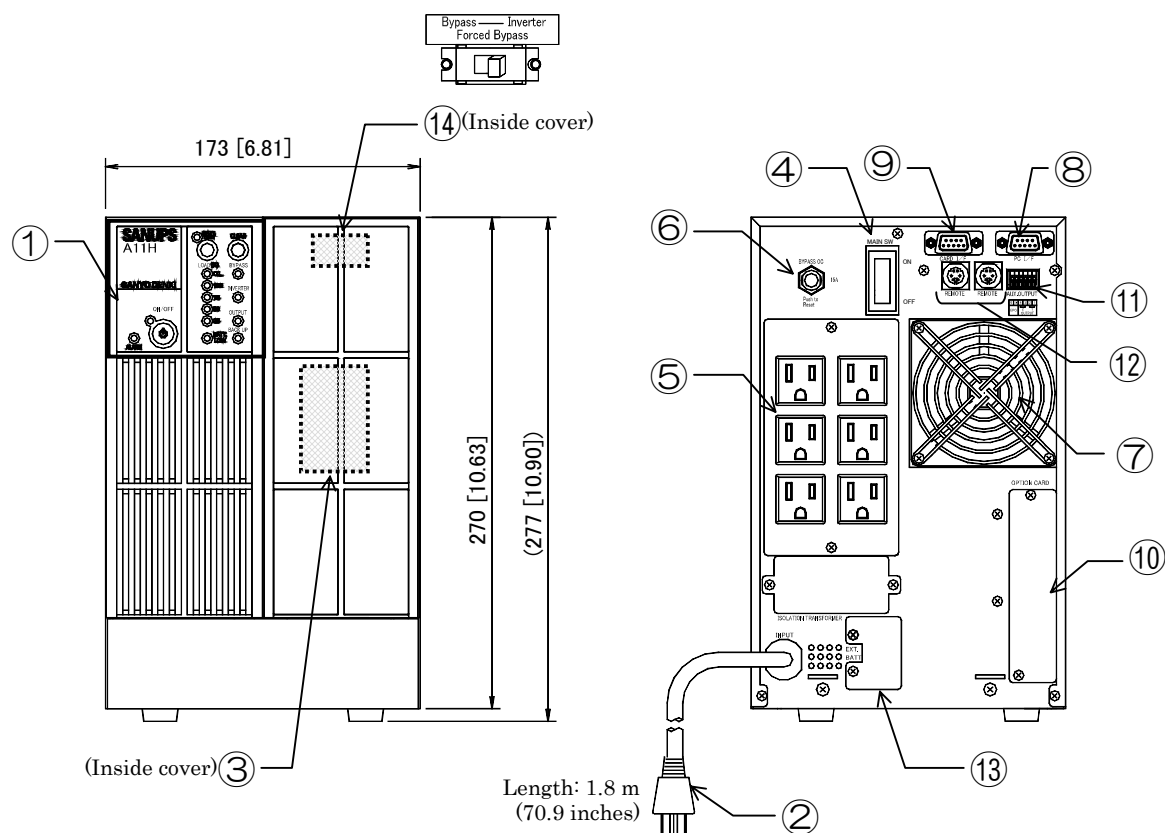

No.	Name	Label	Function
①	Control panel and indicators	-	Control panel for control operations, UPS status display, and function settings
②	Input power plug	-	Input power plug
③	Battery connector	-	Battery connector
④	Input switch	MAIN SW	Input power On and Off switch
⑤	Output terminals	OUTPUT	Power output terminals
⑥	Bypass breaker	BYPASS OC	Breaker to protect bypass circuits
⑦	Exhaust vent for cooling fan	-	Ventilation inside UPS
⑧	PC interface	PC I/F	Connector for the Power control software
⑨	Card interface	CARD I/F	Connector for the Optional interface card*2
⑩	Option card slot	OPTION CARD	Optional interface card*2 slot
⑪	External control terminals	AUX.OUTPUT	Connect an optional system control box *2, or an emergency power off (EPO) switch.
⑫	Remote switch connectors	REMOTE	Connect an optional remote switch *2, or optional linked operation cables.
⑬	Battery connector	EXT.BATT	Battery connector for external battery (optional)*2
⑭	Forced bypass switch*1	Forced Bypass	Switch to bypass power supply during maintenance connecting the maintenance bypass unit (optional)*2

Note

*1. Activate the **Forced Bypass** switch when using a maintenance bypass unit (optional). Normally, do not change the position of this switch. Leave it set to "Inverter".

*2. Contact your supplier or a Sanyo Denki representative for more information about optional equipment. Refer to the Instruction Manual of the optional equipment for details about installation procedures and specifications.

§5.2 Control Panel and Indicators

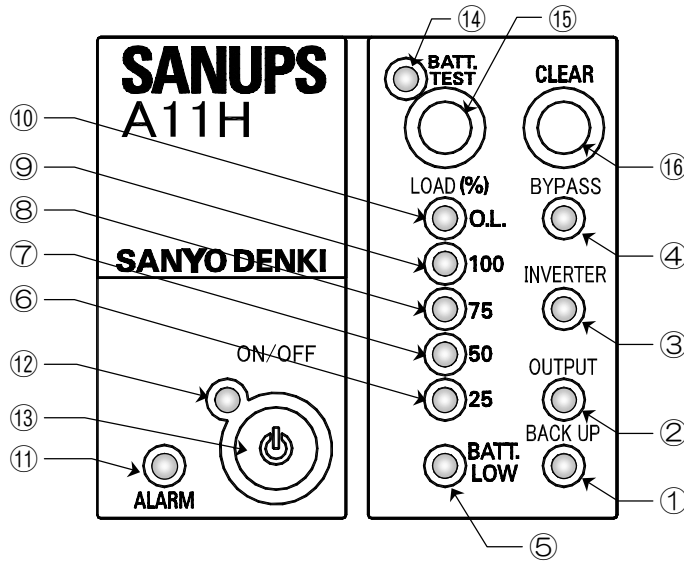

Indications of LED in this manual

The LEDs on the control panel are described as “Green ON/OFF” or “Red ALARM”. The LEDs state are indicated as follows:

☀ : LED lights. ✨ : LED blinks.

No.	Label	Functions				
		Status display	Lit	Not lit	Blink	Fast blink
①	BACK UP	UPS input power status, UPS operation status	AC input power error, Battery back up	AC input power normal	AC input power error, UPS output stop	—
②	OUTPUT	UPS output power status	Output power supply	OFF	Power supply bypassing	During ON/OFF delay operation of output line control operation *2
③	INVERTER	UPS output power status	UPS power supply	OFF	—	—
④	BYPASS	UPS output power status	Bypass power supply	OFF	—	—
⑤	BATT. LOW	Battery status	Battery voltage low, Battery charge is 25 % or less	Battery power normal	Battery exhausted	—
⑥	LOAD (%)	25	Load level 25%	Load 25% or more	Load under 25%	—
⑦		50	Load level 50%	Load 50% or more	Load under 50%	—
⑧		75	Load level 75%	Load 75% or more	Load under 75%	—
⑨		100	Load level 100%	Load 100% or more	Load under 100% *1	—
⑩		O. L.	Overload display	Load 105% or more	Load under 105%	—
⑪	ALARM	Alarm	Failure detected	No failure	—	—
⑫	ON/OFF	Operation status	Output power supply	OFF	Power supply bypassing	During ON/OFF delay operation of Linked operation *3
⑬	ON/OFF	UPS ON/OFF switch				
⑭	BATT. TEST	Battery test	Result: Normal	—	Testing ↓ Blinking speed changes. Result: Error	
⑮	BATT. TEST	Battery test operation				
⑯	CLEAR	Stop buzzer, clear result of battery test				

Note

- *1. For about 5 seconds after **MAIN SW** is set to “ON”, the LOAD “Green 100” blinks.
- *2. Blinks during delay operation when output line control is being performed with an optional outlet box. The blinking is faster than the blinking which indicates UPS bypass power supply.
- *3. Blinks during delay operation when linked operation is being performed with an optional remote switch and optional linked operation cable(s). The blinking is faster than the blinking which indicates UPS bypass power supply.

§5.3 External Interfaces

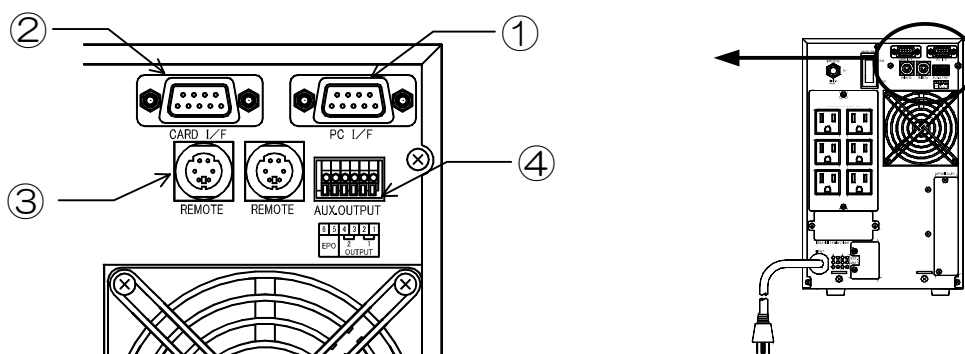

No.	Name	Function
①	PC I/F PC interface (RS-232C)	<p>Connect the computer to this connector with the supplied Network cable. The unit functions as follows, depending on the value of the Interface user setting. Set the Interface setting to select the functions that you want to use. See §3.4 “Setting PC Interface” in the <i>User Settings Guide</i> for details on the setting procedure.</p> <ol style="list-style-type: none"> Interface setting: Workstation <ul style="list-style-type: none"> Select this setting when you want to perform power management and shut down the computer (personal computer, workstation, etc.) by means of communications between the UPS and the computer, using the power management software on the supplied CD-ROM or another power management application. <p>For more information about the power management software, see §16 “How to Use Power Management Software” or the User Guide on the supplied CD-ROM.</p> Interface setting: Standalone <ul style="list-style-type: none"> Select this setting when you want to shut down the UPS automatically, using the standard UPS service* provided by the operating system (NetWare, Windows NT, etc.). <p>* Note about using UPS service functions</p> <ul style="list-style-type: none"> See §17 “Using Standard OS UPS Services” for more information about the setting procedure. Do not connect the supplied Network cable when using an operating system (Windows 95, 98, etc.) that does not have a standard UPS service. Backup may not be possible when a power outage occurs. When using the optional power management software with a serial connection, set the Interface setting to Workstation. The UPS may stop immediately on a power outage if the setting is set to Standalone. <div style="display: flex; justify-content: space-around;"> <div style="text-align: center;"> <p>Signal names</p> </div> <div style="text-align: center;"> <p>External view</p> <p>D-sub 9-pin Male</p> <p>Fixing screw inch</p> </div> </div>

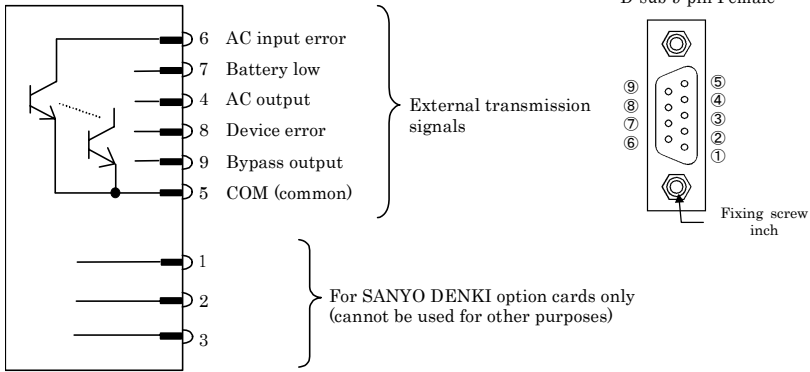
No.	Name	Function												
②	<p>CARD I/F</p> <p>Card interface</p>	<p>This is a dual-purpose interface, for connection of Sanyo option cards (LAN interface card, contact interface card) and for output of UPS status signals.</p> <p>To use the LAN interface card, set the Interface user setting to Workstation (default setting). See §3.4 “Setting PC Interface” in the <i>User Settings Guide</i> for details on the setting procedure.</p> <div data-bbox="847 367 1362 461" style="border: 1px solid black; padding: 5px;"> <p>Note</p> <p>The LAN interface card and the contact interface card cannot be used simultaneously.</p> </div> <div style="display: flex; justify-content: space-around; margin-top: 20px;"> <div data-bbox="549 517 927 546" style="border: 1px solid black; padding: 2px;"> <p>Interface connector terminal names</p> </div> <div data-bbox="1134 517 1294 546" style="border: 1px solid black; padding: 2px;"> <p>External view</p> </div> </div>  <div data-bbox="501 981 820 1010" style="border: 1px solid black; padding: 2px; margin-top: 20px;"> <p>External transmission signals</p> </div> <table border="1" data-bbox="512 1025 1386 1368" style="width: 100%; border-collapse: collapse;"> <thead> <tr> <th style="width: 30%;">Signal name</th> <th>Description</th> </tr> </thead> <tbody> <tr> <td>AC input error</td> <td>Active* when UPS is supplying battery power due to failure of utility power.</td> </tr> <tr> <td>Battery low</td> <td>Active when battery voltage decreases to below the specified level during battery power supply.</td> </tr> <tr> <td>AC output</td> <td>Active when AC power is being supplied to the UPS OUTPUT terminals.</td> </tr> <tr> <td>Bypass output</td> <td>Active when bypass power is being supplied to the UPS OUTPUT terminals.</td> </tr> <tr> <td>Device error</td> <td>Active when a fault occurs in the UPS main unit.</td> </tr> </tbody> </table> <p style="text-align: center; margin-top: 5px;">* Active = transistor conduction state</p> <div data-bbox="501 1442 1059 1471" style="border: 1px solid black; padding: 2px; margin-top: 20px;"> <p>External transmission signal electrical characteristics</p> </div> <ul style="list-style-type: none"> Interface: Transistor open collector output Maximum rating: DC +35V/100mA Normal state: Open (high impedance); Active state: Conduction <div data-bbox="533 1619 676 1648" style="border: 1px solid black; padding: 2px; margin-top: 20px;"> <p>Notes</p> </div> <ul style="list-style-type: none"> When connecting inductive or capacitive loads, do not exceed the maximum rating. When connecting a voltage load, connect - (minus) polarity to the COM (common) pin, and ensure that the maximum rating is not exceeded. <u>Use in excess of the maximum rating or connection of applied voltage with the wrong polarity can result in damage to the UPS.</u> AC voltage cannot be applied. External transmission signals are transistor output. If you require no-voltage contact (relay contact), use the optional contact interface card. 	Signal name	Description	AC input error	Active* when UPS is supplying battery power due to failure of utility power.	Battery low	Active when battery voltage decreases to below the specified level during battery power supply.	AC output	Active when AC power is being supplied to the UPS OUTPUT terminals.	Bypass output	Active when bypass power is being supplied to the UPS OUTPUT terminals.	Device error	Active when a fault occurs in the UPS main unit.
Signal name	Description													
AC input error	Active* when UPS is supplying battery power due to failure of utility power.													
Battery low	Active when battery voltage decreases to below the specified level during battery power supply.													
AC output	Active when AC power is being supplied to the UPS OUTPUT terminals.													
Bypass output	Active when bypass power is being supplied to the UPS OUTPUT terminals.													
Device error	Active when a fault occurs in the UPS main unit.													

No.	Name	Function
③	REMOTE (2) Remote switch connectors	<p>These are connectors for remote ON/OFF signal input and for linked operation.</p> <p>Connect an optional remote switch for remote control of UPS ON/OFF and computer shutdown from a remote location, or connect an optional linked operation cable.</p> <p>These connectors function as follows, depending on the setting of the Interface user setting.</p> <ol style="list-style-type: none"> Interface setting: Standalone <ul style="list-style-type: none"> UPS Remote ON/ UPS Remote OFF Interface setting: Workstation <ul style="list-style-type: none"> UPS Remote ON/One-touch system shutdown By a Remote switch OFF operation, you can perform a one-touch shutdown of computers connected to the UPS from a remote location. <p>Select the Interface setting for the functions you want to use. See §3.4 “Setting PC Interface” in the <i>User Settings Guide</i> for details on the setting procedure.</p> <div style="display: flex; justify-content: space-around;"> <div data-bbox="528 741 917 770" style="border: 1px solid black; padding: 2px;">REMOTE connector terminal names</div> <div data-bbox="1161 741 1326 770" style="border: 1px solid black; padding: 2px;">External view</div> </div> <div style="display: flex; justify-content: space-around; margin-top: 10px;"> <div data-bbox="512 790 943 1182"> </div> <div data-bbox="1118 797 1386 947"> </div> </div> <p>There are 2 REMOTE connectors, each with the same functions.</p> <ul style="list-style-type: none"> For remote control of one UPS unit, connect either of the connectors to a remote switch. For control of multiple UPS units, connect as follows. Connect one of the REMOTE connectors on one UPS unit to a remote switch. Connect a linked operation cable (option) to the other REMOTE connector to link the next UPS. You can connect up to 5 UPS units, and set the ON/OFF delay for each unit, so that you can start and stop the units in sequence. This method of operation is called “Linked operation”. <p>For details, see §18.1 “Remote Switch” and §18.2 “Linked Operation Cable”.</p> <div style="text-align: center; margin-top: 20px;"> <p>Linked operation configuration</p> </div>

No.	Name	Function
④	<p>AUX.OUTPUT</p> <p>External control terminal block</p>	<p>These are terminals for connecting the optional outlet box and for use as EPO terminals*1.</p> <p>Connecting an outlet box to the UPS provides three output lines: OUTPUT0, 1, and 2. You can set ON/OFF delay times for OUTPUT1 and 2, allowing you to control system start and stop. This function is called “Output line control”.</p> <p>*1: EPO is an abbreviation of Emergency Power Off.</p> <div data-bbox="534 454 1353 943" style="text-align: center;"> </div> <p>AUX.OUTPUT (OUTPUT) terminals 1 to 4: Outlet box connection terminals</p> <p>Connect the optional outlet box for control of UPS output lines. In the user settings menu, you can set ON/OFF delay times for OUTPUT1 and OUTPUT2 of the outlet box, allowing you to start and stop connected loads in sequence. For details, see §18.3 “Outlet Box”.</p> <p>AUX.OUTPUT (EPO) terminals 5 and 6: EPO terminals</p> <p>Connect these to the terminals of a switch or other device to enable Emergency Power Off of UPS output.</p> <p>When the switch is pressed in an emergency, the EPO terminals are shorted and UPS output stops. For details, see §18.7 “Connecting the Emergency Power Off (EPO) Terminals”.</p> <div data-bbox="507 1406 1390 1921" style="border: 1px solid black; padding: 10px; margin-top: 20px;"> <p style="text-align: center;">*2 Connecting switch or other contacts to EPO terminals</p> <p>The switch to connect to the EPO terminals is not provided as a standard option for the UPS. Check the following specifications, and use a switch that complies with the specifications, or connect to compliant contacts on your system.</p> <p>EPO terminal specifications</p> <ul style="list-style-type: none"> • Circuit voltage: DC+5V (terminal 6 is - (minus) polarity) • Current when shorted: Approx. 10 mA • EPO operating conditions: Short-circuit terminals 5-6 for 0.2 seconds or longer • EPO terminals: One-touch terminal block (compatible wires: AWG26 to 20) <p>When using a transistor or other semiconductor switch, connect terminal 6 to - (minus) polarity, as shown in the figure. (Connection direction is not specified for nonpolar switches.)</p> <div data-bbox="1061 1702 1364 1904" style="text-align: center;"> </div> </div>

§6. Installation



CAUTION

- When installing the UPS, carefully follow the instructions in this Instruction Manual. Improper installation can result in electric shock, bodily injury, and/or fire.
- Install the UPS on a stable surface that can bear the weight (17 kg, 37.48 lbs). This surface should be flat, so the UPS cannot fall and cause bodily injury.
- The possibility of vibration and shock should be minimized at the installation location.
- All work that involves lifting the UPS should be carried out by at least 2 persons. For safety, put on protective shoes.
- Be careful to avoid straining your lower back when moving and installing the UPS.
- There is a danger that the UPS could fall or be dropped during relocation or installation. Always hold the bottom side of the UPS firmly with both hands. Failure to do so can result in bodily injury or damage to the UPS.

§6.1 Installation Environment Check

Suitable installation environment:

- Ambient temperature: 0 to 40°C (32 to 104°F)
- Relative humidity: 20 to 90%

Do not install the UPS in the following locations:

- Where the ambient temperature exceeds 40°C (104°F).
- Where high humidity may occur.
- Where corrosive gas or salt spray may be present.
- Where it may be subject to vibration and shock.
- Where dust may accumulate.

Note

Battery service life will be foreshortened if the UPS is used in an environment where the ambient temperature exceeds 30°C (86°F). For optimum battery life, install the UPS where the ambient temperature remains between 20 to 25°C (68 to 77°F).

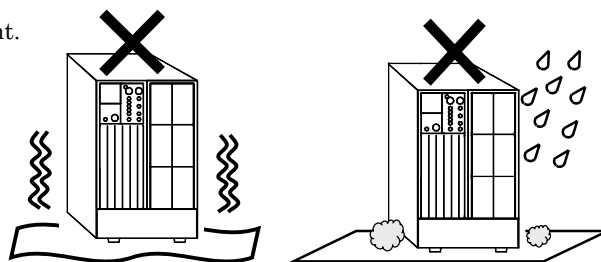

§6.2 Installation Space Check

During installation, provide the following space around the UPS.

- At least 20 cm (about 8 inches) at the front and back as air intake or exhaust space for cooling.
- At least 1 meter (about 40 inches) from CRT displays to allow for slight leakage of magnetic flux. Allow some space from devices which might be affected by magnetic flux.

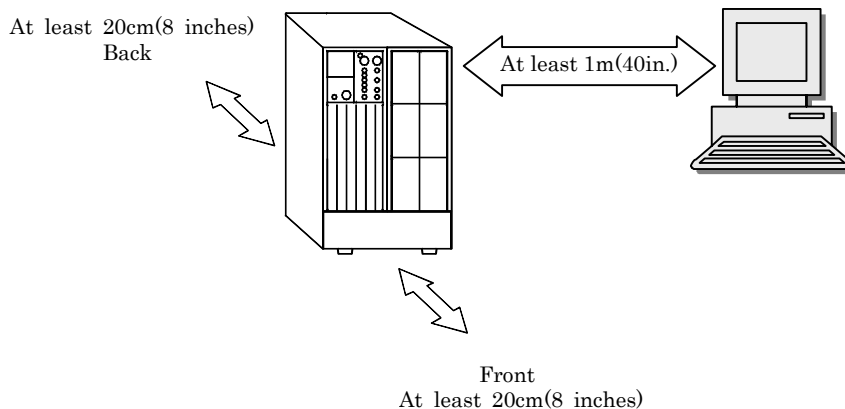

Note for installation

For maintenance of the UPS allow for the space at least 1 meter (40 inches) at the front and 50 cm (20 inches) at the back when needed.

§6.3 Installation

 <p>CAUTION</p>	<ul style="list-style-type: none">• Do not sit, step or lean on the UPS, as bodily injury could result if the UPS was to fall.• The UPS weighs about (17 kg, 37.48 lbs). All work that involves lifting the UPS should be carried out by at least 2 persons. For safety, put on protective shoes. Bodily injury can result if the UPS falls. Be careful to avoid straining your lower back when moving and installing the UPS.• Be careful not to get your hands caught when installing the stand.
---	--

Relocate the UPS to the installation location.

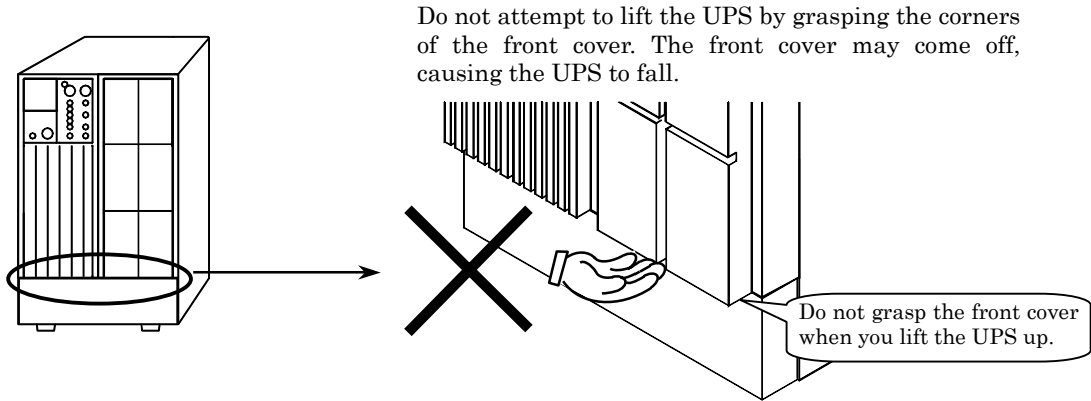

Always install the UPS vertically with the control panel on the top. Do not install horizontally. Do not place other objects on top of the UPS. Doing so can damage the UPS

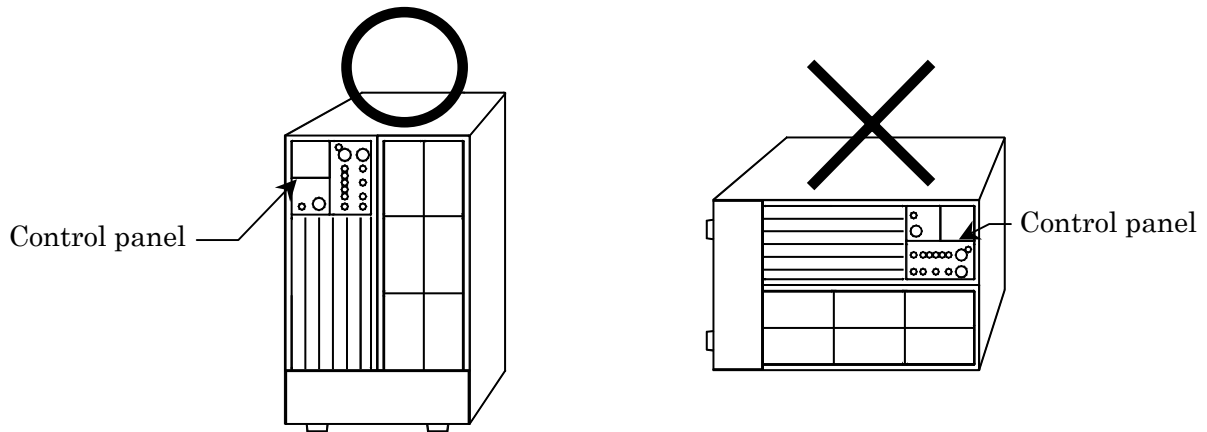

This completes UPS installation.

§7. Wiring

§7.1 Battery Connector Connection



CAUTION

- Wear insulated gloves and take other precautions when connecting the batteries. Otherwise electric shock can result.
- There is a constant voltage (max. approx. 24V : approx. 12V × 2) at the battery terminals. Do not touch them with your hands or short circuit them. Bodily injury can result.
- The battery connector cannot be inserted in the wrong orientation. If it does not go in, do not try to force it. Doing so can damage the connector and result in electric shock.
- Be careful not to get your hands caught when securing the cover.

Connect the battery connectors inside the front cover.
Proceed as follows to connect the battery connectors.

- ① Remove the front panel on the right side of the UPS.
- ② Remove the screw on the bottom side of the battery cover, and then remove the battery cover.
- ③ Remove the insulation tape from the battery connector of the battery pack side.
- ④ Connect the battery connector.

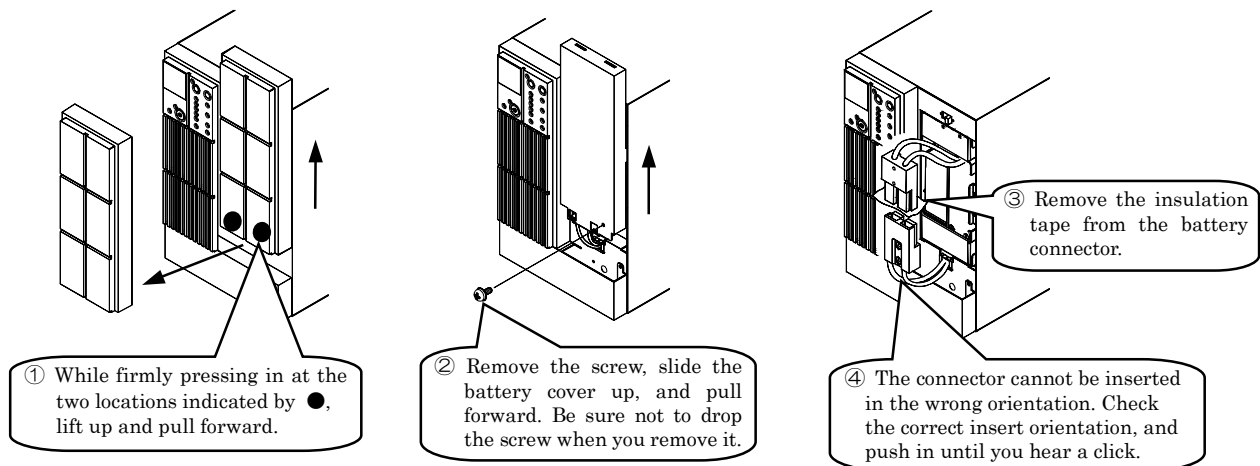

- ⑤ Verify that **Forced Bypass** is set to "Inverter".
- ⑥ Attach the battery cover.
- ⑦ Attach the front panel.

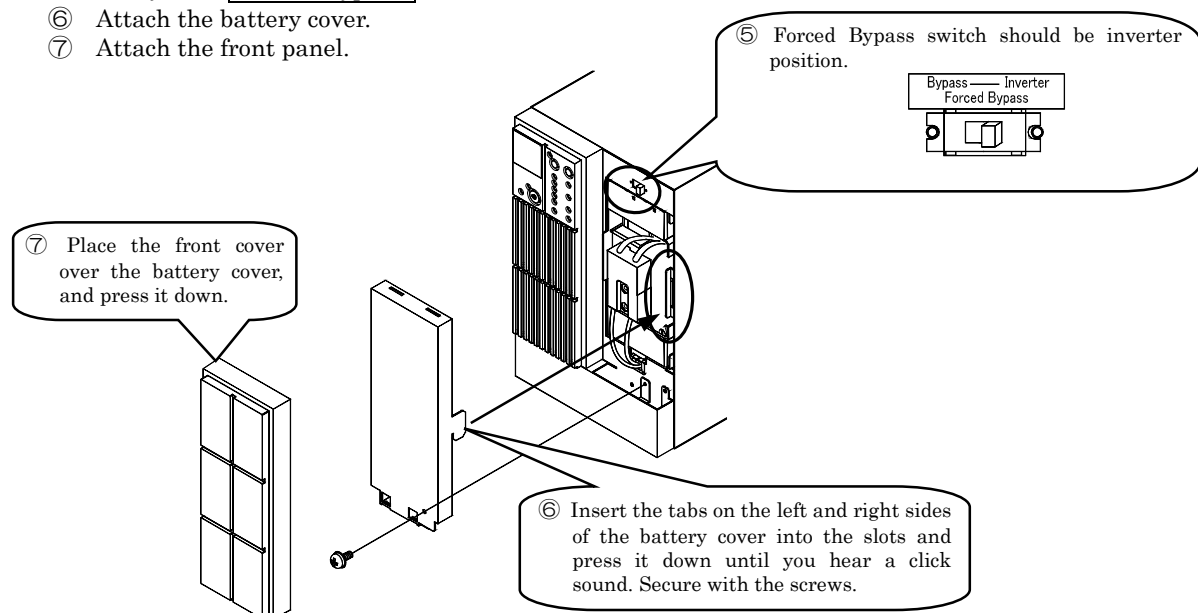

This completes the battery connector connection.

§7.2 Connecting Optional Equipment



Before connecting optional equipment, disconnect the UPS input power plug from the utility power outlet and make sure that the UPS is completely stopped. Failure to do so can result in electric shock.

If you want to use a Network cable or optional equipment, connect them before operating the UPS. If you need to connect them after operating the UPS, do so after completely stopping the UPS and disconnecting the input power plug from the utility power outlet.

For details about wiring and settings, see the descriptions in §16. “How to Use Power Management Software” and §18. “Using Optional Equipment” and the instruction manual supplied with the optional equipment.

Contact your supplier or a SANYO DENKI representative for more information about optional equipment.

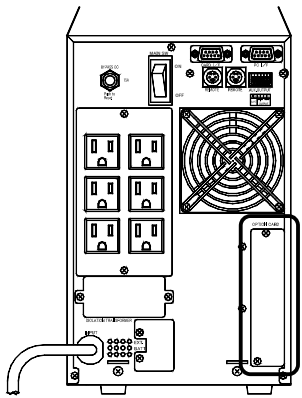

Connecting a Network cable and using the power management software (on supplied CD-ROM) ⇒ §16

Using a LAN interface card ⇒ §18.5
Using a contact interface card ⇒ §18.6

Notes

- The contact interface card and the LAN interface card cannot be used simultaneously.
- The PC I/F connector and the CARD I/F connector cannot be used simultaneously.

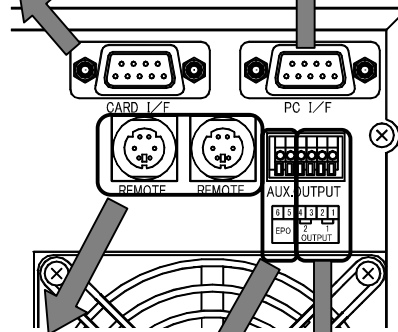

Connecting a remote switch for remote operation ⇒ §18.1 & §18.4
Using linked operation ⇒ §18.2.1~ §18.2.4

Connecting the Emergency Power Off (EPO) terminals ⇒ §18.7

Connecting an outlet box and performing output line control ⇒ §18.3~§18.4

§7.3 Input Plug Connection



- Wiring should be performed only by technically qualified personnel. Incorrect wiring can result in electric shock and/or fire.
- Check that the input power plugs are firmly seated. Failure to do so can result in electric shock, fire, or bodily injury.
- The input power plug must be grounded. Failure to ground it can result in electric shock. Never use the UPS in the place where the UPS input power plug cannot be grounded.

Proceed as follows to connect the input power plug of the UPS.

- ① Check that **MAIN SW** is in the “OFF” position.
- ② Connect the input power plug of the UPS to a utility power outlet.

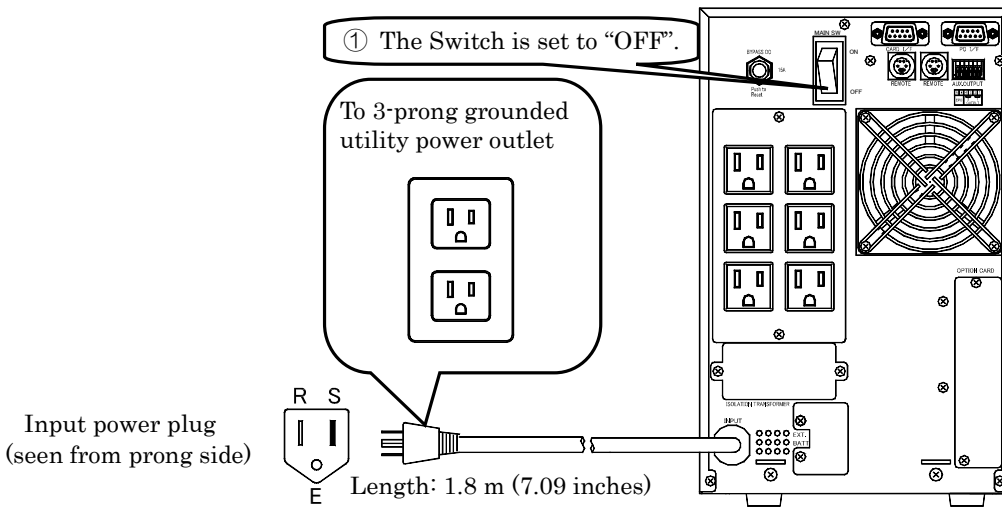

Note

When the AC input power is single-wire grounded, always connect the ground phase to the S terminal (phase) side on the UPS.

Connect as follows if the utility power outlet is a 2-prong type (with no ground terminal).

Connection to the outlet with ground terminal

- ① Insert the adapter to the outlet in the correct direction as shown in the figure.
- ② Connect the grounding wire to the ground terminal.
- ③ Insert the input power plug of the UPS to the adapter.

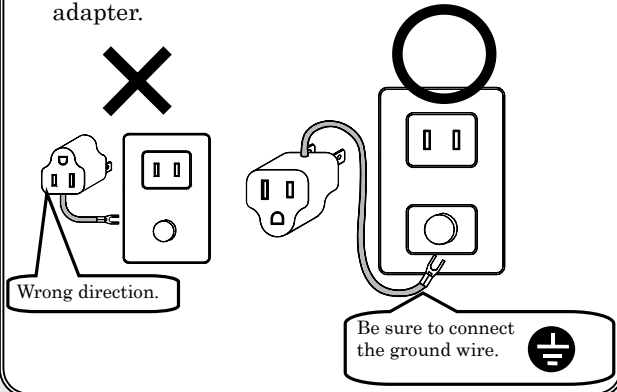

Connection to the outlet without the ground terminal

When the ground terminal is not on the outlet, the ground wiring by technically qualified personnel is required. Contact your supplier. Never use the UPS under the environment where the ground wire cannot be connected.

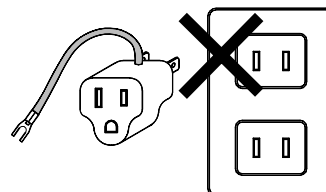

This completes wiring of the UPS.

§8. Procedure Until Load Device Operation

The procedure outline until turning on the load devices is as follows.
 Be sure to follow the procedure outline below to backup the load devices during power outage.

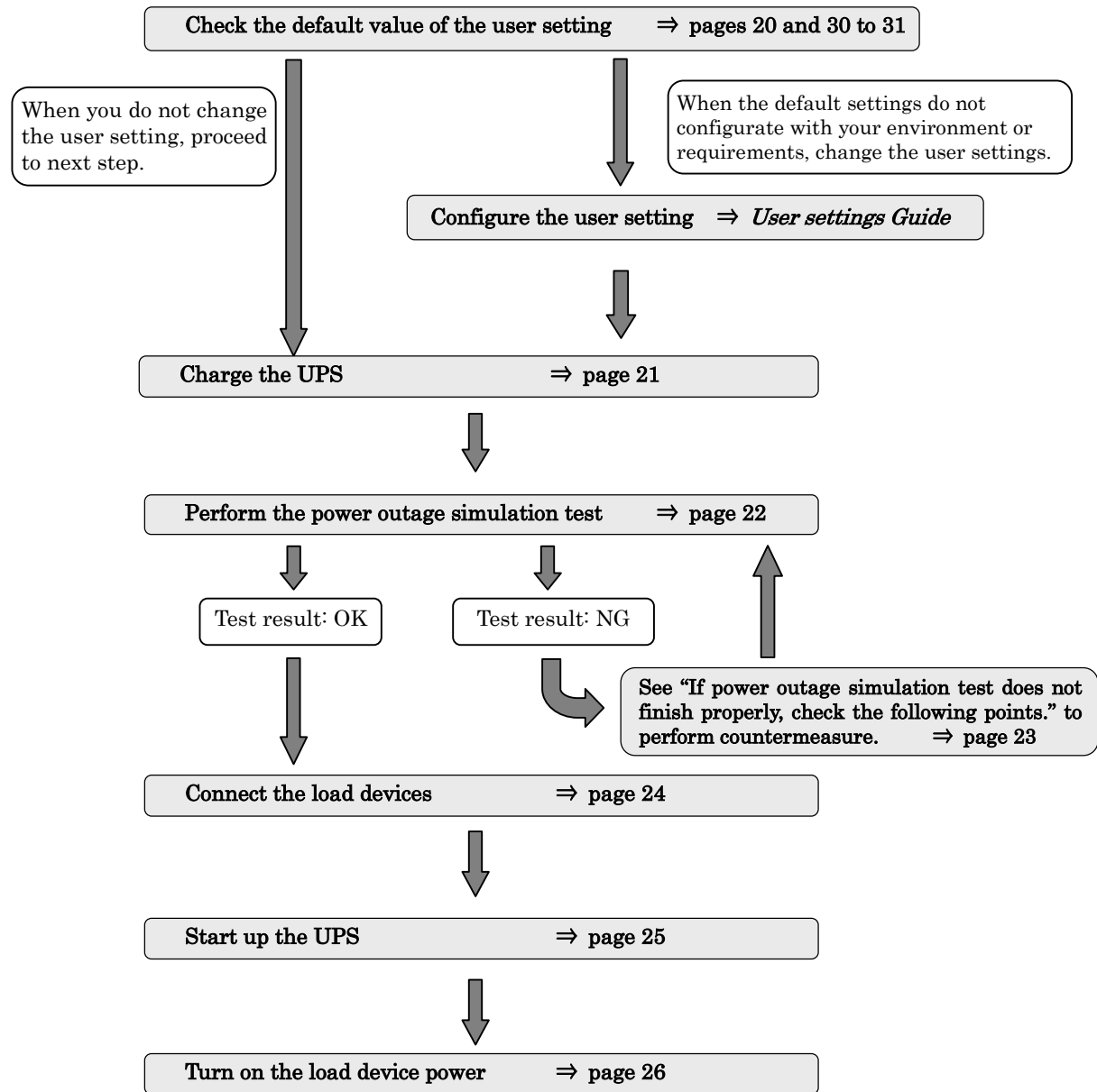

The backup function is available during power outage.

§9. Preparation Before Operation

§9.1 User Settings Check

- ① Check the user settings of the UPS.

See §12.2 “Setup Menu List” to check the setting value. The factory default settings of the UPS are indicated by the “*” mark in the “Default Setting” column in the “Setup Menu List”.

When you use the UPS without changing the user settings, proceed to next step.



Proceed to §9.2 “UPS Charge”.

When the load specification, requirement or your environments do not configure with the default setting of the UPS, change the user setting.



- ② Set **MAIN SW** to “ON”.

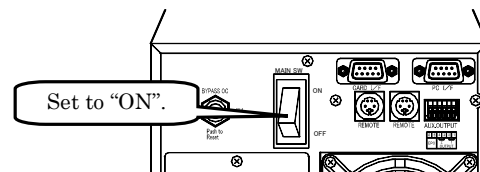

- ③ Configure the user settings. Refer to each item in the *User Settings Guide*.

- ④ Set **MAIN SW** to “OFF”.

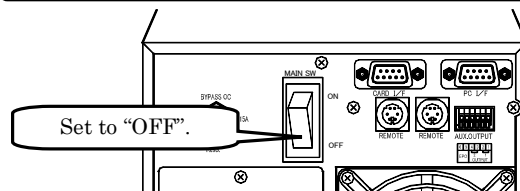

Proceed to §9.2 “UPS Charge”.





Tip

You can also change the user settings after starting load device operation. However, the UPS needs to be restarted for items indicated by RESTART in the “Menu” column of the §12.2 “Setup Menu List”. Setting such items at the preparation stage prior to UPS operation is recommended because the load devices need to be stopped when the UPS is restarted.

§9.2 UPS Charge

At initial startup or when the UPS is not operated for long period, the UPS should be charged for at least 12 hours before operation. Proceed as follows before connecting the load devices.

Indications of Switch and LED in this manual.

The switches are indicated by a frame  .
 Example:  .
 The LEDs on the control panel are described as “Green ON/OFF” or “Red ALARM”.
 The LEDs state are indicated as follows:
 : LED lights.  : LED blinks.

① Set  on the back panel of the UPS to “ON”.

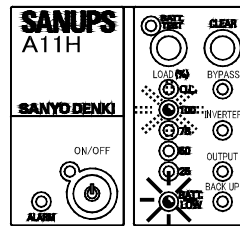
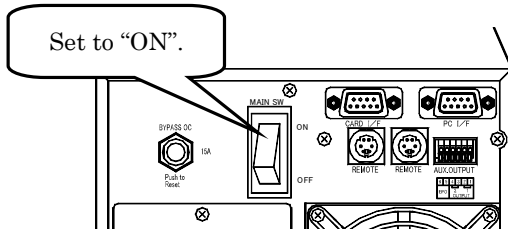

LEDs	
Green 100	Blinking
Red BATT.LOW	lit
↓ after 5 seconds	
Green 100	off
Red BATT.LOW	lit *1

Charging of the UPS starts automatically.

② Operate the UPS for at least 12 hours in this state *2.

Note on the charging time

- *1. “Red BATT.LOW” goes off when the battery charge reaches 25%. However, even if “Red BATT.LOW” goes off, battery charge is not sufficient. Charge the UPS for at least 12 hours.
- *2. The UPS should be charged for at least 12 hours to ensure backup in the event of a power outage, but load devices can be connected for use when the UPS is first activated even if there is insufficient charge because the battery will be charged during operation of the UPS. However, if a power outage occurs at that stage, the full capacity of the backup function may not be available.

This completes the charging of the UPS.

§9.3 Outage Simulation Test

Perform a power outage test to confirm whether the UPS is working properly. Be sure to perform this test prior to connecting the load devices.

Tip

Step ① is not necessary if the procedure in §9.2 “UPS Charge” was performed beforehand.

① Set **MAIN SW** on the back panel of the UPS to “ON”.

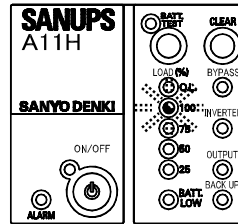
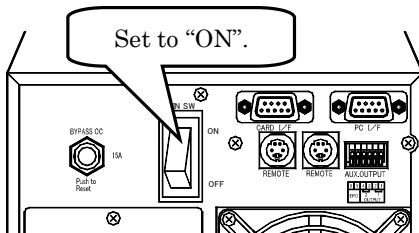

LEDs
Green 100 Blinking
↓ after 5 seconds
All of the LEDs go off

“Red BATT.LOW” will light depending on the battery charge level.

② Press and hold **ON/OFF** for at least 1 second.

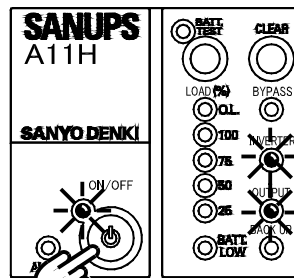

Hold for 1 second.

Buzzer
Musical trill

LEDs
Green ON/OFF Lit
Green OUTPUT Lit
Green INVERTER Lit

③ Check that “Green OUTPUT”, “Green INVERTER” and “Green ON/OFF” lit.

“Green INVERTER” must be lit to perform backup on a power outage.

When the UPS is working properly, the buzzer sound and LED state will be as indicated in steps ④ and ⑤.

④ Set **MAIN SW** to “OFF”.

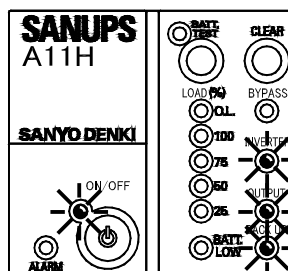
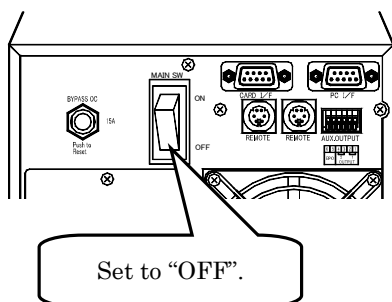

Buzzer
2 beeps..., 2 beeps..., repeated

LEDs
Orange BACK UP Lit
Green ON/OFF Lit
Green OUTPUT Lit
Green INVERTER Lit

⑤ Set **MAIN SW** to "ON".

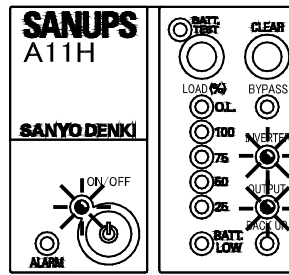
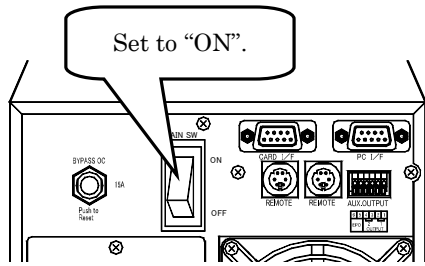

Buzzer
Silent

LEDs
Orange BACK UP Off
Green ON/OFF Lit
Green OUTPUT Lit
Green INVERTER Lit

If power outage simulation test does not finish properly, check the following points.

Possible cause	Countermeasure
The battery connector is not connected.	Connect the battery connector. ⇒ See §7.1 "Battery Connector Connection".
The Forced Bypass switch is set to "Bypass".	Set to "Inverter". ⇒ See the step ⑤ in §7.1 "Battery Connector Connection".
"Green OUTPUT" does not light.	Press and hold  for 1 second. ⇒ See the step ② in §9.3 "Outage Simulation Test".
"Red ALARM" lights.	Contact your supplier.

Contact your supplier or SANYO DENKI when the "Red ALARM" lights or when the UPS does not operate properly even if you perform the countermeasure above.

Check that the UPS operates properly, and then proceed to step ⑥.

⑥ Press and hold  for at least 1 second.

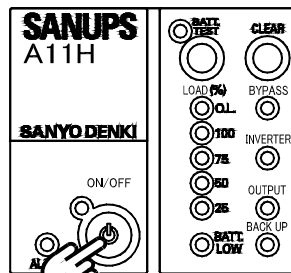

Hold for 1 second.

Buzzer
Musical trill

LEDs
All of the LEDs go off.

⑦ Set **MAIN SW** to "OFF".

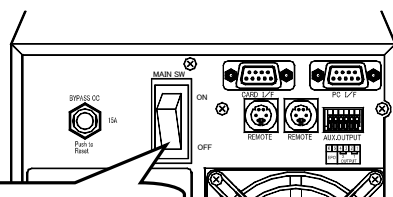

Set to "OFF".

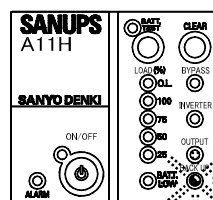

LEDs
Orange BACK UP Blinking
↓ after 5 seconds
All of the LEDs go off

This completes outage simulation test.

§10. Load Devices Connection

Connect the load devices.

- ① Check that the input switch **MAIN SW** is set to “OFF”.
- ② Connect the input power plugs of the load devices to the output terminals.
The total output from all output terminals must not exceed 1kVA (0.7kW).

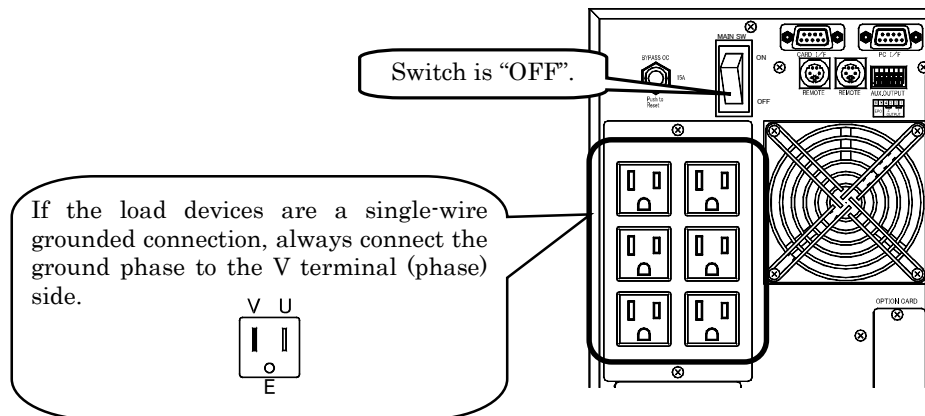

Never connect the following types of load devices to the UPS. 

Load devices	Details
Copy machines, Laser printers, Plain paper fax machines, Overhead projectors, Cleaner and so on	Since such devices are subject to high transient current surges, the UPS will detect the excess current and backup will not be possible when there is a power outage. There is also the risk of the UPS malfunctioning.
Medical equipment, control equipment for elevators and the like, computer systems of public importance	Special considerations such as system redundancy, installation of emergency power generation facilities, need to be given to operation, maintenance, and management.

This completes the load devices connection.



§11. Operating Procedures

Operating procedures differ when you are using optional equipment. Refer to §18. “Using Optional Equipment” and to the Instruction Manual of the optional equipment.

§11.1 UPS Startup

Proceed as follows to start up the UPS.

Indications of Switch and LED in this manual.

The switches are indicated by a frame  .
 Example: **MAIN SW** .
 The LEDs on the control panel are described as “Green ON/OFF” or “Red ALARM”.
 The LEDs state are indicated as follows:
 : LED lights.  : LED blinks.

① Set **MAIN SW** on the back panel of the UPS to “ON”.

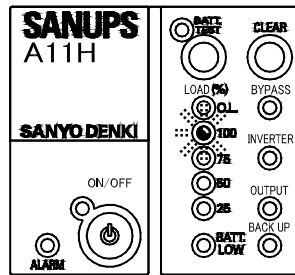
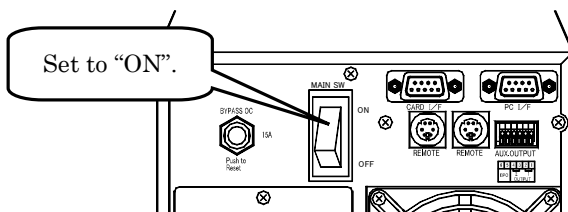

LEDs
 Green 100 Blinking
 ↓ after 5 seconds
 All of the LEDs go off.

Check that all of the LEDs go off, and then proceed to step ②.
 “Red BATT.LOW” will light depending on the battery charge level.

② Press and hold  for at least 1 second.

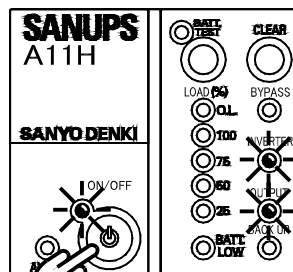

Hold for 1 second.

Buzzer
 Musical trill

LEDs
 Green ON/OFF Lit
 Green OUTPUT Lit
 Green INVERTER Lit

At this step, turn the load device power on.

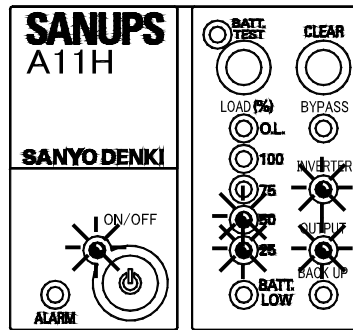

LEDs	
Green ON/OFF	Lit
Green OUTPUT	Lit
Green LOAD 25 -100%	Lit
Green INVERTER	Lit

Note for the load capacity

- “Green LOAD 25 - 100%” will light depending on the connected load capacities.
- If the “Red O.L.” lights and the buzzer sound is emitted (four short beeps followed by another four short beeps), the load devices connected to the UPS exceed the rated capacity of the UPS. Reduce the number of load devices connected.

UPS Battery Power Startup

You can operate the UPS even when the state of the AC input power supply is not good.

You can follow the procedure below to operate the UPS when the AC input power supply is in an abnormal state (power outage, voltage drop, etc.).

Since power is supplied to the load devices from the battery in the UPS when this procedure is used, use the devices for a period of time less than the possible backup time of the UPS.

- ① Check that **MAIN SW** is set to “OFF”.

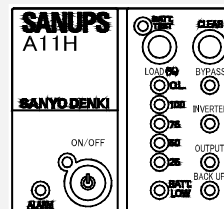
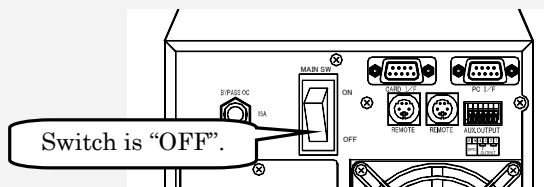

All of the LEDs are off.

- ② Press **ON/OFF** and hold until the buzzer sounds. Release it when the buzzer sounds.

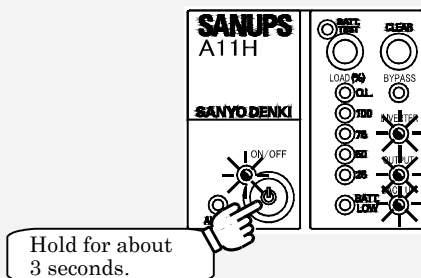

Hold for about 3 seconds.

Buzzer	Musical trill
LEDs	
Green 100	Blinking
↓ after 5 seconds	
Orange BACK UP	Lit
Green ON/OFF	Lit
Green OUTPUT	Lit
Green INVERTER	Lit

* The default setting of the output frequency at UPS startup by this procedure is set to 60 Hz. Change the setting according to the using load devices if needed. See §3.3 “Setting Output Frequency” in the *User Settings Guide* for details.

However, the setting cannot be changed if **MAIN SW** is not set to “ON”, so preset this setting when there is a normal AC input power supply during UPS operation.

§11.2 UPS Shutdown (Daily)

Perform the following operation to shut down the UPS daily. Be sure to shut down the load devices prior to shutting down the UPS.

① Press and hold  for at least 1 second.

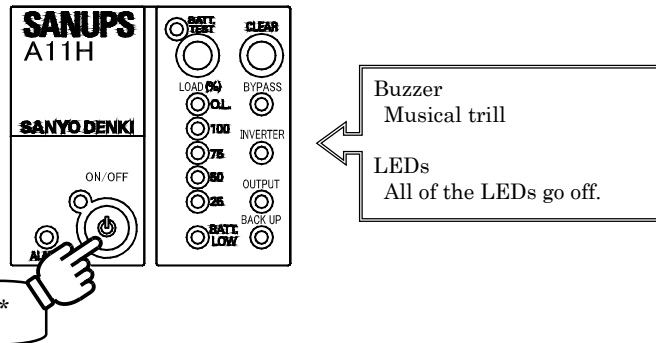

Hold for 1 second.*

* Operation varies depending on the user setting of “Shutdown operation”. See §3.8 “Setting UPS Shutdown Operation” in the *User Settings Guide* for details.

Note
Do not touch **MAIN SW** when you perform a daily shutdown. Leave it set to “ON”.

§11.3 UPS Shutdown (If Not to Be Used for More than a Week)

Perform the following operation if the UPS is not to be used for at least a week. Be sure to shut down the load devices prior to shutting down the UPS.

- ① Press and hold  for at least 1 second.

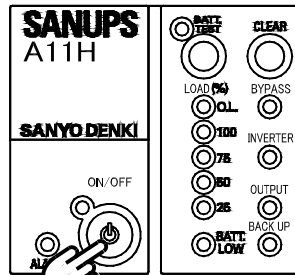

Buzzer
Musical trill
LEDs
All of the LEDs go off.

Hold for 1 second.*

* Operation varies depending on the user setting of “Shutdown operation”. See §3.8 “Setting UPS Shutdown Operation” in the *User Settings Guide* for details.

- ② Set **MAIN SW** to “OFF.”

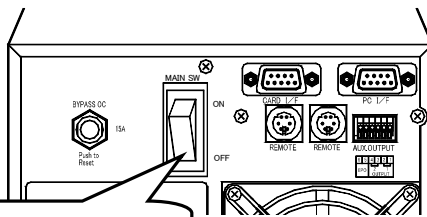

② Set to “OFF”.

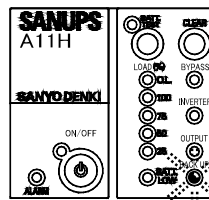

LEDs
Orange BACK UP Blinking
↓ after 5 seconds
All of the LEDs go off

Note

If input power is shut off while the UPS is operating, the batteries are discharged as if a power outage occurred. Be aware that when the input supply is restored, the full capacity of the backup function will not be available until the batteries have had time to recharge.

§12. User Settings

The UPS has a user settings menu, described in §12.2 “Setup Menu List”. You can set the various menu items to configure the UPS according to your environment, your applications, and the specifications of the connected load devices. For details of setup operations of each menu, see the *User Settings Guide*.

§12.1 Prior to Modifying the User Settings

The factory default setting of the UPS is indicated by the “*” mark in the “Default Setting” column. Configure each menu according to your environment and requirements. Whenever you change a menu item setting, we recommend that you place a check mark in the “Current Setting” column field of the Setup Menu List.

All of the user setting menu items can be selected and set by display LED blinking pattern.

Setup menu list and the blinking pattern of indicators on the control panel are illustrated in the following figure.

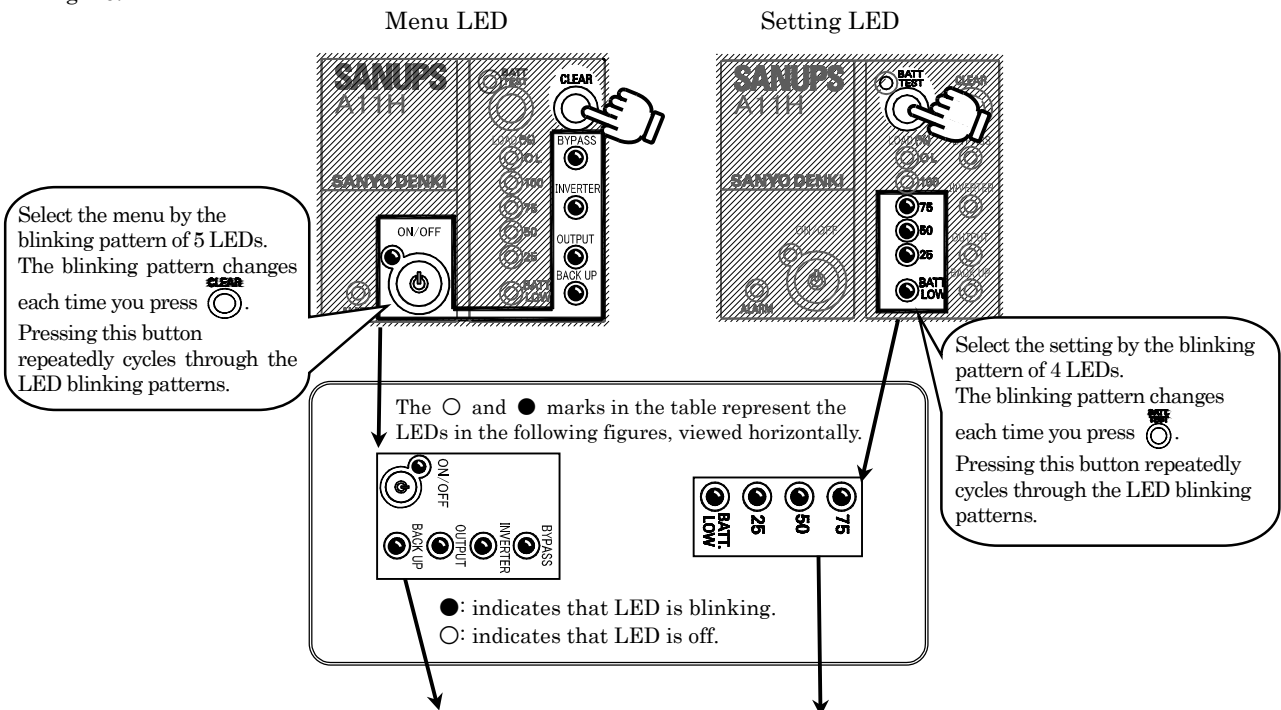

No.	User Settings Guide		Menu	Menu LED	Setting	Setting LED	Default Setting	Current Setting	Remarks
	Ref. page	Item							
1	4	3.1	Output voltage	○ ● ○ ○ ○	-	● ○ ○ ○			
					-	○ ● ○ ○			
					120V	○ ○ ● ○	*		
2	5	3.2	Frequency sync range (RESTART)	○ ○ ● ○ ○	1%	● ○ ○ ○			
					3%	○ ● ○ ○		✓	
					5%	● ● ○ ○	*		

Indicates the section numbers of sections with reference information for each item. See the indicated sections in the *User Settings Guide* for detailed information.

For the menus indicated by “RESTART” in this column, restart of the UPS is required.

The factory default setting.

Place a check mark when you change the setting.

Note

When you change the setting of the menus indicated by RESTART in the “Menu” column, its changes do not take effect until you restart the UPS. If a restart is required, be sure to power off the load devices before resetting. See §11.3 “UPS Shutdown (If Not to Be Used for More Than a Week)” for information about how to shut down the UPS, and §11.1 “UPS Startup” for information about how to start the UPS.

§12.2 Setup Menu List

●: indicates that LED is blinking.
○: indicates that LED is off.

No.	User Settings Guide Ref. page	Item	Menu	Menu LED	Setting	Setting LED	Default Setting	Current Setting	Remarks
1	4	3.1	Output voltage	○ ●○○○	Do not use this setting.	●○○○			Do not use this setting.
					Do not use this setting.	○●○○			Do not use this setting.
					Do not use this setting.	●●○○			Do not use this setting.
					120 V	○○●○	*		120 V
2	5	3.2	Frequency sync range (RESTART)	○ ○●○○	1%	●○○○			±1%
					3%	○●○○			±3%
					5%	●●○○	*		±5%
3	6	3.3	Output frequency (RESTART)	○ ●●○○	50Hz	●○○○			50Hz
					60Hz	○●○○	*		60Hz
4	7	3.4	PC interface	○ ○○●○	Standalone	●○○○			Set when using UPS remote ON/OFF or Standard OS UPS Services
					Workstation	○●○○	*		Set when using a power management software, LAN card or UPS remote ON and One-touch system shutdown.
					Serial Login	●●○○			Shutdown by serial login.
					Do not use this setting.	○○●○			Do not use this setting.
5	8	3.5	Serial baud rate	○ ●●○○	9600	●○○○	*		9600 bps.
					4800	○●○○			4800 bps.
					2400	●●○○			2400 bps.
6	9	3.6	UPS operation upon power recovery	○ ○●●○	Auto	●○○○	*		Auto restart
					OFF	○●○○			The UPS stays off.
					30%	●●○○			Auto restart when battery charge reaches 30%.
					50%	○○●○			Auto restart when battery charge reaches 50%.
7	10	3.7	Buzzer sound	○ ●●●○	All patterns	●○○○	*		All sounds
					Pattern 1	○●○○			Emit sounds on serious failure and battery trouble.
					Pattern 2	●●○○			Emit alarm and key click sounds.
					OFF	○○●○			Emit key click sounds only.
8	11	3.8	Shutdown operation	○ ○○○●	1 second	●○○○	*		Turn the UPS off when pressed for 1 second.
					3 seconds	○●○○			Turn the UPS off when pressed for 3 second.
					Special operation	●●○○			Turn the UPS off on special operation.
9	12	3.9	Overload recovery operation	○ ●○○●	Auto return	●○○○			Auto recovery when a certain period of time has elapsed.
					Bypass	○●○○	*		Fixed as bypass power supply on overload.
10	13	3.10	UPS operation at  OFF (RESTART)	○ ○●○○	OFF	●○○○	*		The UPS stays off.
					Bypass	○●○○			Bypass power supply
11	14	3.11	Low battery voltage warning timing	○ ●●○○	Battery voltage	●○○○	*		When low battery voltage level is detected.
					2 minutes	○●○○			When remaining battery duration is 2 minutes.
					3 minutes	●●○○			When remaining battery duration is 3 minutes.
12	15	3.12	Battery backup time	○ ○○●○	5 minutes	●○○○	*		5 minutes backup
					20 minutes	○●○○			20 minutes backup
					30 minutes	●●○○			30 minutes backup
					40 minutes	○○●○			40 minutes backup
					60 minutes	●●○○			60 minutes backup
					Do not use this setting.	○●○○			Do not use this setting.
					Do not use this setting.	●●○○			Do not use this setting.
					Do not use this setting.	○○●○			Do not use this setting.
13	16	3.13	Battery type	○ ●○○●	5 years	●○○○	*		5 years lifetime type
					10 years	○●○○			10 years lifetime type
					3 years	●●○○			3 years lifetime type
14	17	3.14	Battery test schedule	○ ○●○○	180 days	●○○○	*		Test batteries every 180 days.
					90 days	○●○○			Test batteries every 90 days.
					30 days	●●○○			Test batteries every 30 days.
					None	○○○○			No battery check.
15	18	3.15	Reset battery information	○ ●●○○	Do not reset	●○○○	*		Do not reset.
					Reset	○●○○			Reset the battery information when you replace the battery.



User Settings

No.	User Settings Guide		Menu	Menu LED	Setting	Setting LED	Default Setting	Current Setting	Remarks
	Ref. page	Item							
16	19	3.16	Linked delay operation	● ○ ○ ○ ○	No delay	● ○ ○ ○ ○	*		Linked ON/OFF delay disabled (operate with delay of 0 seconds)
					Delay	○ ● ○ ○ ○			Linked ON/OFF delay enabled (operate with specified delay)
17	20	3.17	Linked operation ON delay time	● ● ○ ○ ○	0 seconds	● ○ ○ ○ ○	*		Set the ON/OFF delay times when you conduct linked operation. Delay operation is not enabled unless item §3.16 "Enabling and Disabling Linked Operation Delay" in the <i>User Settings Guide</i> is set to "Delay".
					10 seconds	○ ● ○ ○ ○			
					30 seconds	● ● ○ ○ ○			
					1 minute	○ ○ ● ○ ○			
					3 minutes	● ○ ● ○ ○			
					5 minutes	○ ● ● ○ ○			
					10 minutes	● ● ● ○ ○			
					15 minutes	○ ○ ● ● ○			
18	21	3.18	Linked operation OFF delay time	● ○ ● ○ ○	0 seconds	● ○ ○ ○ ○	*		
					10 seconds	○ ● ○ ○ ○			
					30 seconds	● ● ○ ○ ○			
					1 minute	○ ○ ● ○ ○			
					3 minutes	● ○ ● ○ ○			
					5 minutes	○ ● ● ○ ○			
					10 minutes	● ● ● ○ ○			
					15 minutes	○ ○ ○ ● ○			
19	22	3.19	Output line control (Restart)	● ● ● ○ ○	Disabled	● ○ ○ ○ ○	*		Disable system control
					Enabled	○ ● ○ ○ ○			Enable system control
20	23	3.20	Outlet box OUTPUT1 ON delay time	● ○ ○ ● ○	0 seconds	● ○ ○ ○ ○	*		Set the ON delay times for the OUTPUT1 and OUTPUT2 terminals of the outlet box. The delay times are not enabled unless item §3.19 "Enabling and Disabling Output line Control" in the <i>User Settings Guide</i> is set to "Enabled".
					5 seconds	○ ● ○ ○ ○			
					30 seconds	● ● ○ ○ ○			
					1 minute	○ ○ ● ○ ○			
					5 minutes	● ○ ● ○ ○			
					10 minutes	○ ● ● ○ ○			
21	24	3.21	Outlet box OUTPUT2 ON delay time	● ● ● ○ ○	0 seconds	● ○ ○ ○ ○	*		
					6 seconds	○ ● ○ ○ ○			
					35 seconds	● ● ○ ○ ○			
					1 minute	○ ○ ● ○ ○			
					30 seconds	● ○ ● ○ ○			
					10 minutes	○ ● ● ○ ○			
22	25	3.22	Outlet box OUTPUT1 OFF delay time	● ○ ● ● ○	0 seconds	● ○ ○ ○ ○	*		Set the OFF delay times for the OUTPUT1 and OUTPUT2 terminals of the outlet box. The delay times are not enabled unless item §3.19 "Enabling and Disabling Output line Control" in the <i>User Settings Guide</i> is set to "Enabled".
					10 seconds	○ ● ○ ○ ○			
					30 seconds	● ● ○ ○ ○			
					1 minute	○ ○ ● ○ ○			
					3 minutes	● ○ ● ○ ○			
					5 minutes	○ ● ● ○ ○			
23	26	3.23	Outlet box OUTPUT2 OFF delay time	● ● ● ● ○	0 seconds	● ○ ○ ○ ○	*		
					10 seconds	○ ● ○ ○ ○			
					30 seconds	● ● ○ ○ ○			
					1 minute	○ ○ ● ○ ○			
					3 minutes	● ○ ● ○ ○			
					5 minutes	○ ● ● ○ ○			
24	27	3.24	Outlet box OUTPUT1 power outage output time	● ○ ○ ○ ●	Until batteries exhausted	● ○ ○ ○ ○	*		Set the power outage output times for the OUTPUT1 and OUTPUT2 terminals of the outlet box. The delay times are not enabled unless item §3.19 "Enabling and Disabling Output line Control" in the <i>User Settings Guide</i> is set to "Enabled" and item §3.4 "Setting PC Interface" in the <i>User Settings Guide</i> is set to "Standalone".
					0 seconds	○ ● ○ ○ ○			
					30 seconds	● ● ○ ○ ○			
					1 minute	○ ○ ● ○ ○			
					3 minutes	● ○ ● ○ ○			
25	28	3.25	Outlet box OUTPUT2 power outage output time	● ● ○ ○ ●	Until batteries exhausted	● ○ ○ ○ ○	*		
					0 seconds	○ ● ○ ○ ○			
					30 seconds	● ● ○ ○ ○			
					1 minute	○ ○ ● ○ ○			
					3 minutes	● ○ ● ○ ○			
26	29	3.26	Operation of Outlet box OUTPUT0 after stopping of OUTPUT1 and 2	● ○ ● ● ○	Stop power supply	● ○ ○ ○ ○	*		Set the operation of OUTPUT0 after output from the OUTPUT1 and 2 terminals has stopped. This setting is not enabled unless item §3.19 "Enabling and Disabling Output line Control" in the <i>User Settings Guide</i> is set to "Enabled".
					Continue power supply	○ ● ○ ○ ○			
27	30	3.27	Ring signal	● ● ● ● ○	Output	● ○ ○ ○ ○	*		Output a Ring signal when the UPS starts.
					Do not output	○ ● ○ ○ ○			Do not output a Ring signal when the UPS starts.

Note

When you change the setting of the menus indicated by RESTART in the "Menu" column, its changes do not take effect until you restart the UPS. If a restart is required, be sure to power off the load devices before resetting. See §11.3 "UPS Shutdown (If Not to Be Used for More Than a Week)" for information about how to shut down the UPS, and §11.1 "UPS Startup" for information about how to start the UPS.

§13. Maintenance

 CAUTION	<ul style="list-style-type: none"> • Internal maintenance and inspection should be performed only by technically qualified personnel. Electric shock, injury, burning, fuming or fire could otherwise result. • Before beginning inspection, shut down the UPS completely, and remove the input power. Failure to do so may result in an electric shock. • While the batteries are connected to the equipment, hazardous voltage is present. Never touch any parts with your hand. Doing so may result in an electric shock. • Batteries should be replaced periodically. • Batteries used after their service life has passed may cause a fire. 	 
---	---	--

The projected service life of the UPS is about 7 years. During this period, the battery must be replaced periodically. If you intend to continue using the UPS after its projected service life, components other than the battery also need to be replaced (a fee will be charged). Contact your supplier. If these components are not replaced at the end of the service life, the UPS may not function properly.

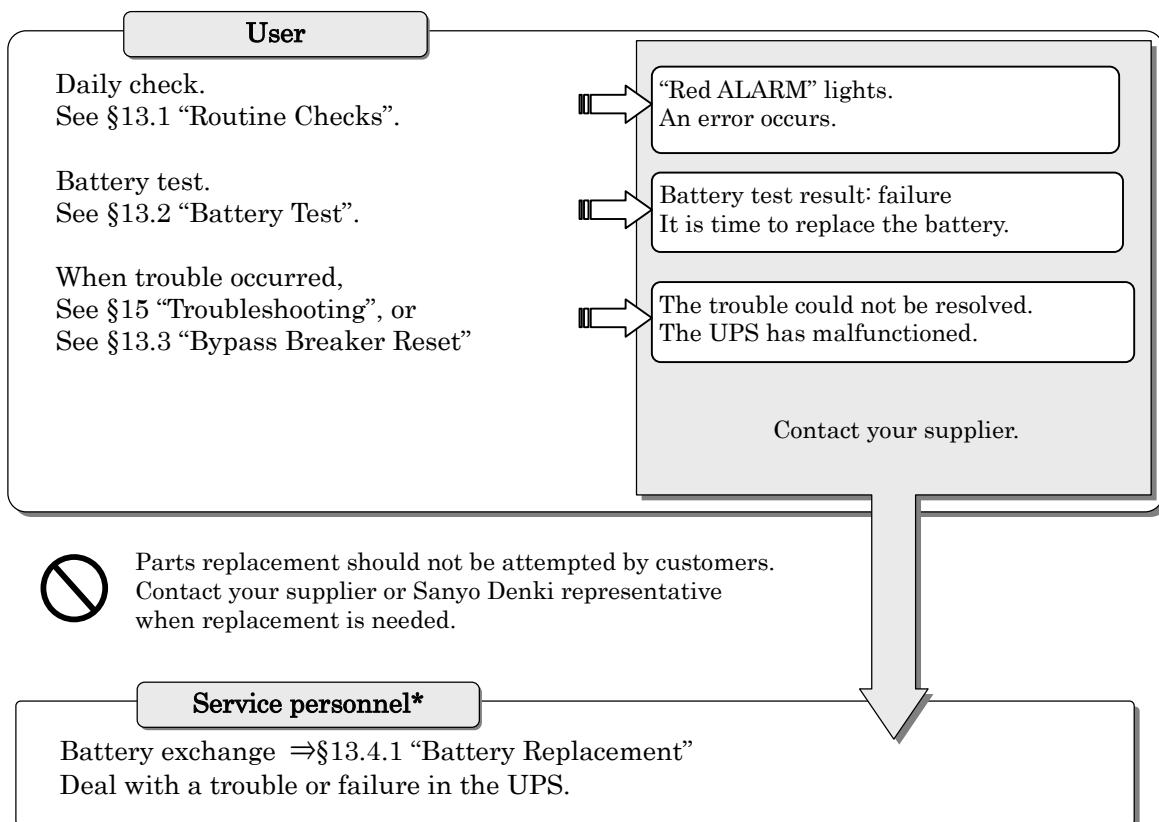

There are routine checks to be performed by the user and maintenance to be performed by service personnel. Some maintenance items are not able to be performed by the user, so be sure to submit a request for such work to your supplier when maintenance is required.



* What are service personnel?

This term is used to indicate service technicians from SANYO DENKI or entrusted from SANYO DENKI with knowledge of this UPS. Maintenance work must not be performed by other than a qualified service technician.

§13.1 Routine Checks

 CAUTION	<ul style="list-style-type: none"> • Be sure not to inspect the inside of the UPS. Doing so may result in an electric shock, burn, injury, smoke, or fire. • Do not touch the fan on the back panel of the UPS when cleaning the UPS or anywhere around the UPS. Doing so may result in an injury. • Do not use, for example, a wet cloth for cleaning. Doing so may result in an electric shock. • When cleaning, do not connect a vacuum cleaner to the outlet of the UPS. Doing so may result in smoke or fire. 	
---	--	---

Routinely check the following items.

- ① **Is the control panel LED lighting state abnormal?**
⇒ See §15 “Troubleshooting” to perform the countermeasure.
- ② **Is the buzzer sounding?**
⇒ If any buzzer sounds, see §14 “Alarm Sounds” to perform the countermeasure.
- ③ **Is the exterior of the UPS in any way damaged or deformed?**
- ④ **Is an unusual sound or odor emitted from the UPS?**
- ⑤ **Is the installation environment of the UPS suitable?**
Are things like humidity and temperature within the specified ranges?
⇒ See §6.1 “Installation Environment Check”.
- ⑥ **Has the specified amount of space been provided at the front and back of the UPS?**
If the air intake or exhaust vent is blocked, the internal temperature of the UPS rises, which could result in a damage of the UPS.
⇒ See §6.2 “Installation Space Check”.
- ⑦ **Remove any dust or dirt adhering to the intake and exhaust vents.**
Dust or dirt adhering to parts inside the UPS may cause it to malfunction.
- ⑧ **Perform the battery backup time test periodically.**
When the UPS is shipped from the factory, it is set up to perform an automatic battery test once every 6 months. If you change the setting to “None”, periodically perform a manual battery backup test. Refer to §13.2 “Battery Test”. Depending on the results of the test, exchange the battery.

Estimated battery replacement interval

Battery service life is affected by operating conditions such as ambient temperature and the number of discharge cycles.

Ambient temperature has a particularly strong influence as indicated in the following table.

Average Ambient Operating Temperature	Projected Service Life	Battery Replacement Interval
25°C (77°F)	5 years	4.5 years
30°C (86°F)	3.5 years	3 years
35°C (95°F)	2.5 years	2 years
40°C (104°F)	1.7 years	1.5 years

Using a battery after its service life has expired may result in battery leakage, and in the worse case, smoke, and fire. Request that the battery be replaced early as a preventative measure.

§13.2 Battery Test

You can perform tests of the built-in and externally connected batteries. You can do this without stopping the load devices connected to the UPS.

When it is shipped from the factory, the UPS is set up to perform an automatic battery test once every 6 months. To change the automatic battery test schedule, see §3.14 “Setting Battery Test Schedule” in the *User Settings Guide*.

Follow the procedure below when conducting a manual battery test. However, if the UPS has performed a backup operation within 12 hours prior to the test, the result may show an error. The test should, therefore, be conducted when the UPS has not performed a backup operation within the last 12 hours.

- ① Press  and hold it for at least 2 seconds.

The “Green BATT. TEST” indicator starts blinking, and the battery test starts.

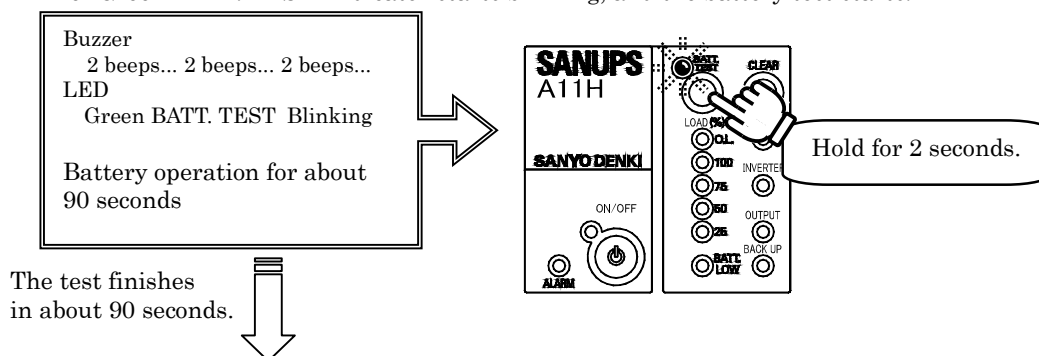

Check the “Green BATT. TEST” indicator for the results of the test.

Battery Test Results	Green BATT. TEST	lit	blink
	Buzzer	—	***** 7 beeps ... ***** 7 beeps ...
Confirmed Backup Time	90 seconds or more	Less than 90 seconds	
Result	The batteries are OK.	Replacing the battery early is recommended. Contact SANYO DENKI.	

- ② After the battery test has finished and the “Green BATT. TEST” indicator lights or blinking, press .

The “Green BATT. TEST” indicator goes off and returns to its normal indication.

Note

The results of the test are only an approximate guide. If the batteries have reached their replacement interval, an early replacement is recommended even if the results of the test are OK. See “Estimated battery replacement interval” in the previous page for more information.

Stopping battery test

- To stop the battery test while it is underway,
 - Press  for at least 2 seconds ⇒ The UPS returns to normal operation.
- The battery test stops if any of the following 1-3 occur or if any of the following 4-7 is operated while it is underway.

<ol style="list-style-type: none"> 1. Input power error (voltage or frequency). 2. Mechanical failure 3. Output power overload 	<ol style="list-style-type: none"> 4. Switching of Forced Bypass switch 5. Setting MAIN SW to “OFF” 6. Pressing  for 1 second or longer 7. Executing the battery test stop by the power control software
---	---

The “Green BATT. TEST” indicator does not display the results of the test if the test is interrupted.

§13.3 Bypass Breaker Reset



- Always power the UPS off before resetting the bypass breaker. Failure to do so can cause electric shock. Be careful to avoid injury or electric shock.

If the bypass breaker trips, the “Red ALARM” indicator lights and output from the output terminals stops.

Proceed as follows to reset the bypass breaker.

- ① Stop the UPS by setting **MAIN SW** to “OFF”.
- ② Examine if there are neither a problem nor a trouble in the equipment of the load.
- ③ Press the bypass breaker on the back panel of the UPS.
- ④ Set **MAIN MCCB** to “ON”, and then start the UPS by pressing ^{ON/OFF}  and holding it for 1 second. For details about UPS startup, see §11.1 “UPS Startup (Normal Operation)”.

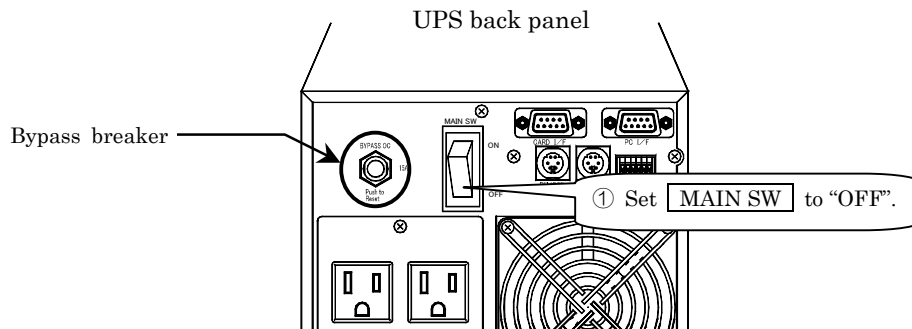

Note

If you reset the bypass breaker while the UPS is powered on, the “Red ALARM” indicator will remain lit until you power the UPS off. Always power the UPS off before resetting the bypass breaker.

This completes the bypass breaker reset.

§13.4 Maintenance by Service Personnel

The user must not perform the maintenance described in this section.
Be sure to contact your supplier for maintenance.



 CAUTION	<ul style="list-style-type: none"> • Internal maintenance and inspection should be performed only by technically qualified personnel. Electric shock, injury, burning, fuming or fire could otherwise result. • Batteries should be replaced periodically. Batteries used after their service life has passed may cause a fire. • Never use organic chemicals such as gasoline, thinner, benzene or detergent to clean batteries. These can cause the casing to crack and leak, resulting in fire or current leakage. • Do not touch the rotating fan at maintenance. Doing so may result in bodily injury. • Never use a wet cloth to clean the UPS. Doing so may result in an electric shock. • When cleaning, do not connect a vacuum cleaner to the outlet of the UPS. Doing so may result in smoke or fire.
--------------------	--

§13.4.1 Battery Replacement

You can replace the batteries without stopping the load devices. However, this should be done as quickly as possible, because the UPS will be unable to provide backup power in the event of a power outage.

 CAUTION	<ul style="list-style-type: none"> • The battery pack weighs about 6 kg (13.23 lbs). Be careful not to drop it on your feet. Bodily injury can result. • Wear insulated gloves and take other precautions when replacing the batteries. Otherwise electric shock can result. • There is a constant voltage (max. approx. 24 V: approx. 12 V × 2) at the battery terminals. Do not touch them with your hands or short-circuit them. Bodily injury can result.
--------------------	--

- ① Check the replacement battery model name.

Mode name: HRL1234WF2FR (manufactured by CSB BATTERY Co., LTD.)

Note on battery replacement

This UPS uses the battery HRL1234WF2FR manufactured by CSB BATTERY Co., LTD. Since this battery is designed specifically for the UPS, do not use a different battery. Do not substitute with any other type, and do not mix new and old batteries, as shortened battery life, leakage, and heat could result.

- ② Remove the front panel on the right side of the UPS.
 ③ Remove the screw on the bottom side of the battery cover, and then remove the battery cover.
 ④ Disconnect the battery connector.

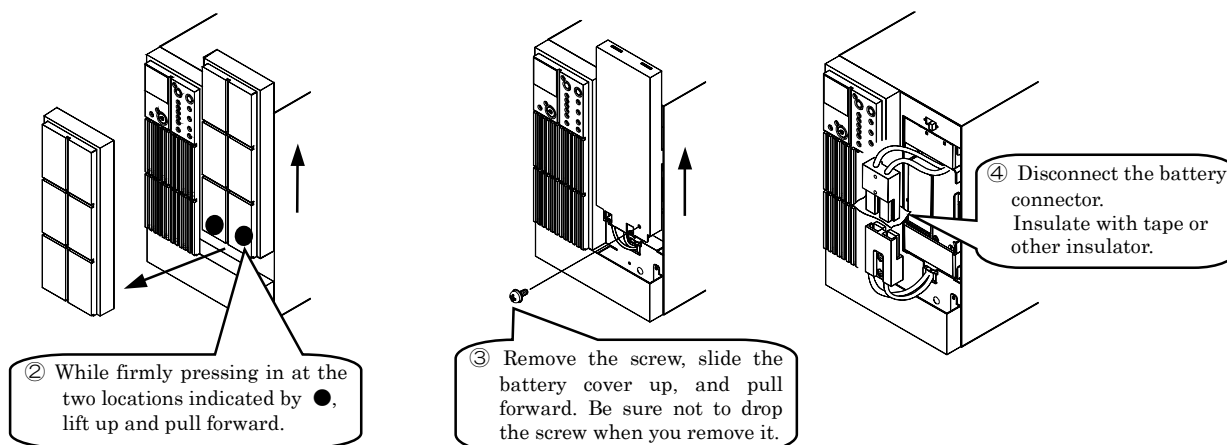

- ⑤ Pull the battery pack out.
- ⑥ Insert the new battery pack so that the connector faces forward.

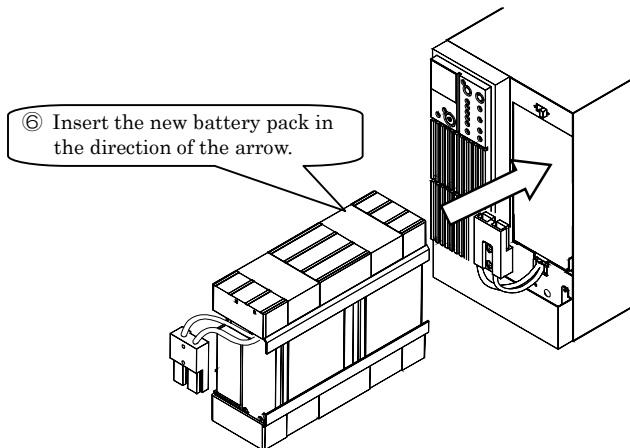

⑥ Insert the new battery pack in the direction of the arrow.

- ⑦ Connect the battery connector.
- ⑧ Verify that **Forced Bypass** is set to “Inverter”.
- ⑨ Attach the battery cover.
- ⑩ Attach the front panel.

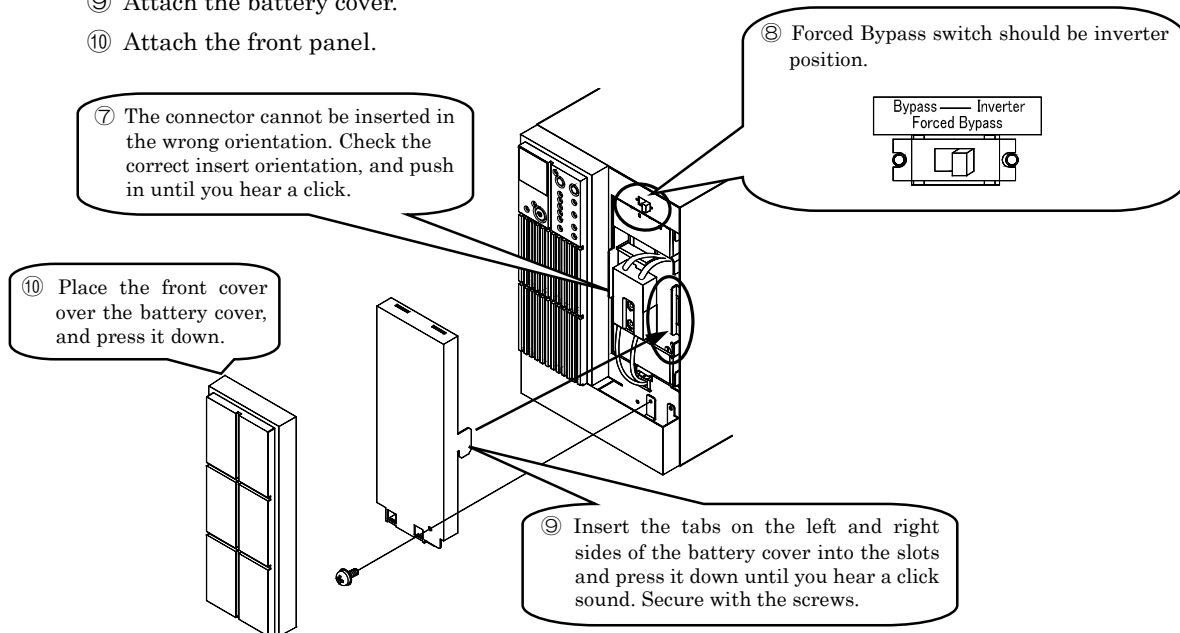

⑦ The connector cannot be inserted in the wrong orientation. Check the correct insert orientation, and push in until you hear a click.

⑧ Forced Bypass switch should be inverter position.

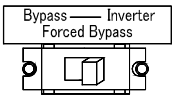

⑩ Place the front cover over the battery cover, and press it down.

⑨ Insert the tabs on the left and right sides of the battery cover into the slots and press it down until you hear a click sound. Secure with the screws.

 CAUTION	<ul style="list-style-type: none"> • The battery connector cannot be inserted in the wrong orientation. If it does not go in, do not try to force it. Doing so can damage the connector and result in electric shock. • Be careful not to get your hands caught when securing the cover.
--------------------	--

- ⑪ Set the backup time in the user setting. See §3.12 “Setting Battery Backup Time ”in the *User Settings Guide*.
- ⑫ Set the battery type in the user setting. See § 3.13 “Setting Battery Type” in the *User Settings Guide*.
- ⑬ Reset the battery information in the user setting. See §3.15 “ Resetting Battery Information” in the *User Settings Guide*.

Note on the used battery

The batteries used in this product are lead type batteries which are a reusable resource. Please cooperate by recycling when replacing or disposing of used batteries. Dispose of used batteries according to the instructions. To dispose of used batteries, contact your nearest sales representative, an authorized industrial waste handling company, or repack them in their original cartons and send them to your supplier. (An extra charge is required.)

This completes the battery exchange.

§14. Alarm Sounds

The buzzer sounds to indicate an UPS status error or change. Check the sound pattern and refer to the following table for the steps to take.

Tip

Press to stop the buzzer.

Sound Pattern	LED Status	UPS Status	What to Do
Continuous tone * _____	Red ALARM lit	This is a mechanical failure.	Contact your supplier.
	Red ALARM lit	During bypass operation The bypass breaker is tripped.	Reset the bypass breaker. See §13.3 “Bypass Breaker Reset”.
	Red ALARM lit Red BATT.LOW lit	The battery is exhausted.	When utility power is restored, the UPS will restart automatically depending on the setting value of “UPS Operation Upon Power Recovery” in the user setting. Refer to §3.6 “Setting UPS Operation Upon Power Recovery” in the <i>User Settings Guide</i> .
2 seconds * * *... 1 beep 1 beep 1 beep	Red Bypass lit	Bypass power supply	<ul style="list-style-type: none"> Check Forced Bypass is set to “Inverter”. This switch is located inside the front panel of the unit. Remove the front panel to check. See §7.1 “Battery Connector Connection”, step ⑤. The UPS operation switched to bypass operation due to overload. Reduce the number of load devices connected to the UPS. Check the setting of “UPS Operation at OFF” in the user setting menu. It may be set to “Bypass”.
2 seconds ** ** **... 2 beeps 2 beeps 2 beeps	Orange BACK UP lit	Power is being supplied from the battery because of an input voltage or frequency error.	Verify that the input voltage and input frequency are within the rated range. Refer to §19.4 “Specifications”.
	Orange BACK UP lit	MAIN SW was set to “OFF” during UPS power supply.	Set MAIN SW to “ON”.
	Green BATT.TEST blinking	The UPS is performing a battery check.	Wait for the battery check to end. You can stop the battery check by pressing and holding it for at least 2 seconds.
Continuous beeps ***** ...	Red BATT.LOW lit	The battery voltage is low.	<ul style="list-style-type: none"> Verify that the input voltage and input frequency are within the rated range. Refer to §19.4 “Specifications”. MAIN SW may be set to “OFF”. If MAIN SW is “OFF”, set it to “ON”.
1 sec. 2 sec. **** ****...	Red O.L. lit	The load devices connected to the output exceed the rated capacity of the UPS.	Connect fewer load devices to the output.
2 seconds ***** *****... 7 beeps 7 beeps	Green BATT.TEST blinking Red BATT.LOW lit	“When UPS starts” The battery connectors are not connected.	Stop the UPS, refer to §7.1 “Battery Connector Connection”, and firmly connect the battery connectors. After connecting the battery connectors, start the UPS, and check to make sure that buzzer sounds are not heard and that “Green BATT. TEST” does not blink. “Red BATT. LOW” goes off when battery charge is 25% or more, “Red BATT. LOW” remains lit when battery charge is 25% or less.
	Green BATT.TEST blinking	“Performing the battery test” The battery check result was an error.	Perform the battery test. Refer to §13.2 “Battery Test”. When the same result persists, the battery must be replaced. Contact your supplier.
2 seconds ***** *****... 5 beeps 5 beeps	-	Remaining battery service life is six months.	A battery replacement is recommended. Contact your supplier. You can press to stop the buzzer sound.
	Red BATT.LOW blinking	The battery has reached its service life.	The battery must be replaced. Contact your supplier. You can press to stop the buzzer sound and “Red BATT.LOW” blinking, but they will start again the next time the UPS is powered on. This will continue until you replace the battery.







Note

Contact your supplier if any other failure occurs in the UPS.

§15. Troubleshooting

 CAUTION	<ul style="list-style-type: none"> • Internal maintenance and inspection should be performed only by technically qualified personnel. Electric shock, injury, burning, fuming or fire could otherwise result. • Before beginning inspection, shut down the UPS completely, and remove the input power. Failure to do so may result in an electric shock. • While the batteries are connected to the UPS, hazardous voltage is present. Never touch any parts with your hand. Doing so may result in an electric shock.
---	---

If a problem occurs, check the condition of the UPS and perform countermeasures listed in the table below.

UPS Status	LED Status	Countermeasure
When the UPS starts, "Green BATT.TEST" blinks, "Red BATT.LOW" lit and the buzzer sounds	Green BATT.TEST blinking Red BATT. LOW lit	<ul style="list-style-type: none"> • Check that the battery connectors are connected properly. Stop the UPS, refer to §7.1 "Battery Connector Connection", and firmly connect the battery connectors. After connecting the battery connectors, start the UPS, and check to make sure that buzzer sounds are not heard and that "Green BATT.TEST" does not blink. "Red BATT. LOW" goes off when battery charge is 25% or more, "Red BATT. LOW" remains lit when battery charge is 25% or less.
Battery charge is 25% or less.	Red BATT. LOW lit	<ul style="list-style-type: none"> • Charge the battery in the UPS. Refer to §9.2 "UPS Charge".
No output power is supplied from the outlet of the UPS.	Green OUTPUT off	<ul style="list-style-type: none"> • Check whether the input wiring has been performed correctly. Refer to §7 "Wiring". • Verify that the input voltage and input frequency are within the rated range. See §19.4 "Specifications". •  must be pressed for at least 1 second. See §11.1 "UPS Startup" for the correct startup procedure.
	All off	<ul style="list-style-type: none"> • Check that MAIN SW is set to "ON". See §11.1 "UPS Startup" for the correct startup procedure.
	Orange BACK UP blinking	<ul style="list-style-type: none"> • Verify that the input voltage and input frequency are within the rated range. See §19.4 "Specifications".
	Red ALARM lit	<ul style="list-style-type: none"> • The bypass breaker may be tripped. See §13.3 "Bypass Breaker Reset".
Output power from outlet of the UPS does not stop.	Green OUTPUT lit	<ul style="list-style-type: none"> •  must be pressed for at least 1 second. See §11.2 "UPS Shutdown (Daily)" for the correct shutdown procedure. However, bypass power supply continues if bypass operation was started by changing over with the forced bypass switch, overload, or failure. • Check the setting of "UPS Shutdown Operation" in the user setting menu. It may be set to "3 seconds" or "Special operation". The factory default setting is "1 second". See §3.8 "Setting UPS Shutdown Operation" in the <i>User Settings Guide</i>.
	Green OUTPUT blinking	<ul style="list-style-type: none"> • Check the setting of "UPS Operation at  OFF" in the user setting menu. It may be set to "Bypass". The factory default setting is "OFF". See §3.10 "Setting UPS Operation at  OFF" in the <i>User Settings Guide</i>.
Output power from outlet of the UPS stops during operation.	All off	<ul style="list-style-type: none"> •  may be turned off by accidental operation. Turn on .
	Red ALARM lit	<ul style="list-style-type: none"> • Check whether the bypass breaker on the back panel is tripped. It may have been tripped by an overload or short circuit. Check the total load and the possibility of a short circuit. When the total load is high, reduce the number of load devices connected to the UPS. See §13.3 "Bypass Breaker Reset".
Output power from outlet of the UPS stops during power outage.	Red ALARM lit, Red BATT.LOW lit	<ul style="list-style-type: none"> • Check whether the battery has deteriorated. Check the time to replace the battery. The battery service life will differ depending on the ambient temperature. Earlier battery replacement is recommended. • Check whether there was a power outage within the last 12 hours. The battery level may be low. Sufficiently charge the UPS.
Alarm buzzer sounds.	-	<ul style="list-style-type: none"> • The alarm buzzer sounds when an error, abnormal state, or alarm condition is detected in the UPS. See §14 "Alarm Sounds".

UPS Status	LED Status	Countermeasure
Alarm buzzer does not sound.	-	<ul style="list-style-type: none"> The alarm buzzer sound may be set to "OFF". Check the setting of "Buzzer Sound" in the user setting menu. See §3.7 "Setting Buzzer Sound" in the <i>User Settings Guide</i>.
Battery power supply continues. Power supply switches to battery power frequently.	Orange BACK UP lit	<ul style="list-style-type: none"> Check whether MAIN SW on the back panel of the UPS is set to "ON". (If MAIN SW is set to the "OFF" during normal operation, the same operation as for a utility power source failure will be triggered.). Verify that input voltage and input frequency are within the rated limits. See §19.4 "Specifications".
UPS does not switch from bypass power supply to UPS power supply.	Green OUTPUT blinking, Green ON/OFF blinking	<ul style="list-style-type: none"> Check Forced Bypass is set to "Inverter". This switch is located inside the front panel of the unit. Remove the front panel to check. See §7.1 "Battery Connector Connection", step⑤. When "Overload Recovery Operation" in the user setting menu is set to "Auto return": The UPS switches to UPS power supply every 2.5 seconds, and switches back to bypass power supply if the overload condition still persists. This cycle is repeated. See §3.9 "Setting Overload Recovery Operation" in the <i>User Settings Guide</i>. When "Overload Recovery Operation" in the user setting menu is set to "Bypass": If the utility power voltage is low and the load current is below the overload detection threshold when the UPS switches to bypass power supply, the UPS continues to switch between UPS power supply and bypass power supply. See §3.9 "Setting Overload Recovery Operation" in the <i>User Settings Guide</i>.
Cannot perform battery test.	-	<ul style="list-style-type: none"> A battery test cannot be performed when: <ol style="list-style-type: none"> Inverter is stopped. Bypass power supply is active. Input voltage or input frequency is out of range. Shutdown under remote control is in progress. UPS is defective.
When using the power management software, serial communication fails.	-	<ul style="list-style-type: none"> Check that "Interface" in the user setting menu is set to "Workstation". See §3.4 "Setting PC Interface" in the <i>User Settings Guide</i>, and §5.3 "External Interfaces". The factory default setting is "Workstation". Check the setting of "Serial Baud Rate" in the user setting menu. The factory default setting is "9600". Select the same setting value as the setting of power management software.
Automatic UPS restart does not occur after shutdown due to battery exhaustion following power outage.	-	<ul style="list-style-type: none"> Check the setting of "UPS Operation Upon Power Recovery" in the user setting menu. Automatic UPS restart does not occur if this item is set to "OFF". If this item is set to "30%", "50%", or "80%", the UPS does not start until the batteries are charged to the specified level. The factory default setting of this item is "Auto". See §3.6 "Setting UPS Operation Upon Power Recovery" in the <i>User Settings Guide</i>.
The UPS does not automatically start at the time set for scheduled operation in the power management software.	-	<ul style="list-style-type: none"> If "When power failure recovered, automatically start the UPS" of the "6.4 (4) Configuring the UPS control conditions" items described in the user guide of the power management software is selected and the value "10 to 90" is set for the specified value (%), the UPS will not start even at a scheduled start time if the battery is not charged to the specified value. When scheduling operation for the UPS, set this specified value (%) to "0". For details, refer to "6.4 Setting the Shutdown Conditions" in the User Guide of the power management software.
"Red ALARM LED" is lit.	-	<ul style="list-style-type: none"> An alarm condition or error has occurred. Contact your supplier.

Note

When the troubles cannot be resolved even if you perform the countermeasures above, or when other failure occurs in the UPS, contact your supplier.

§16. How to Use Power Management Software

What is Power Management Software “SANUPS SOFTWARE STANDALONE” (supplied CD-ROM)?

This software is used for power supply control or management from the computer by communicating the UPS to a computer (personal computer or workstation).

Install power management software on your computer.

For more information, refer to the Install Guide and User Guide in the CD-ROM of the power management software.

The following is the minimum system configuration required for the setup and operation of the SANUPS SOFTWARE STANDALONE.

Computer: AT compatible

CPU: Pentium III® 500MHz (or greater)

Memory: Minimum of 32 MB (64 MB or more recommended)

Available disk space: Minimum of 64MB

Display: Minimum 640 x 480 pixel resolution

Supported OS: Windows® NT 4.0 (*1), Windows® 2000, Windows® XP, Windows® Server 2003(*2)

(*1) Service Pack 6 or above

(*2) Standard Edition or Enterprise Edition

- ① Check that “Interface” in the user setting is set to “Workstation”. The factory default setting is “Workstation”. See §3.4 “Setting PC Interface” in the *User Settings Guide* for how to set.
- ② Connect the “PC/I/F” connector of UPS to the computer using the supplied network cable.
- ③ Check that network cable connection is not loose.

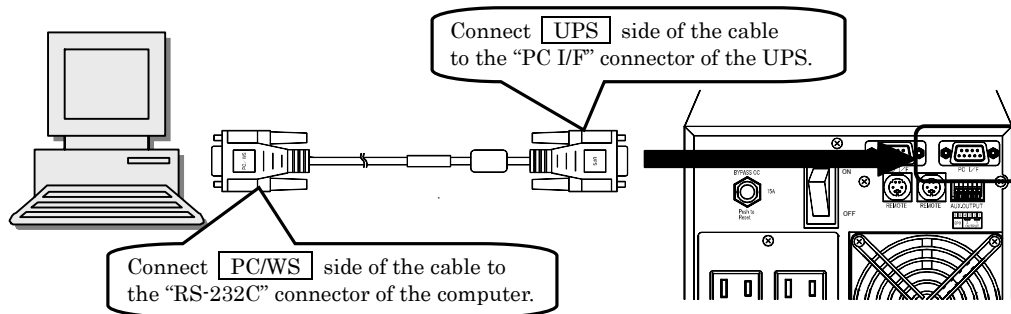

Note

See §5.3 “External Interfaces” for the details of the PC I/F connector.
The CARD I/F and PC I/F connectors cannot be used at the same time.

- ④ Insert the SANUPS SOFTWARE STANDALONE CD-ROM into the CD-ROM drive to install this program.
The installation program starts automatically. Proceed as instructed on the screen.
- ⑤ After completing the software installation, reboot the computer.
- ⑥ Launch the SANUPS SOFTWARE STANDALONE from the Windows Start menu to set up.

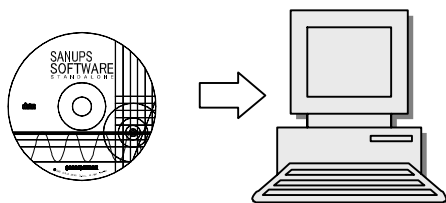

Tip

If the installation program does not start automatically, double-click Setup.exe on the CD-ROM to start installation manually.

This completes preparation to use SANUPS SOFTWARE STANDALONE.
For more usage information, refer to the Install Guide and User Guide in the CD-ROM of the power management software.

Usage Notes for Power Management Software

When using the supplied “SANUPS SOFTWARE STANDALONE”, note the following instructions for the items on the main screen.

See §6.1 “Main Screen” in the User Guide of SANUPS SOFTWARE STANDALONE for details.

Main screen of SANUPS SOFTWARE STANDALONE

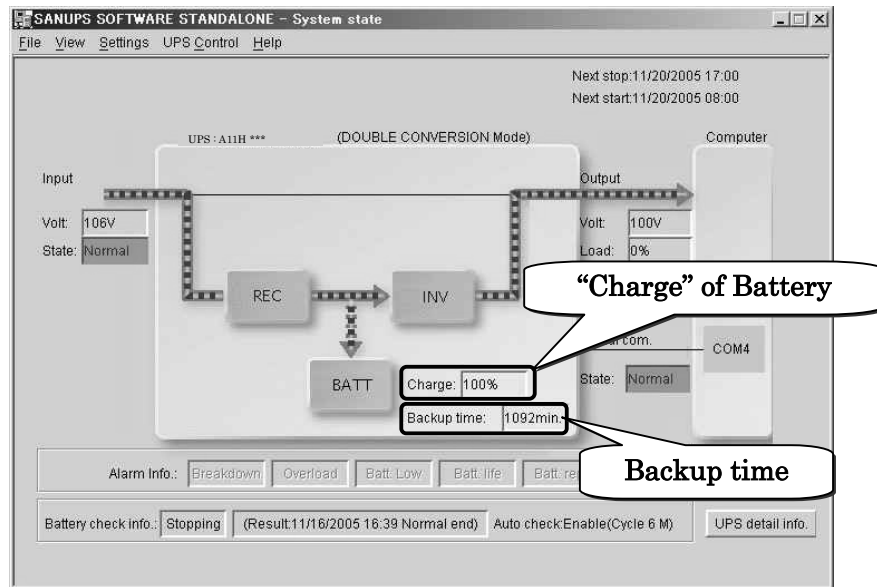

“Charge” of Battery

- (1) If UPS is not charged for 12 hours or more when the UPS first started, “Charge” is not displayed properly. See §9.2 “UPS Charge” to charge the UPS.
- (2) If the UPS is stopped and then restarted, even when the UPS is charged enough, “Charge” might be displayed as “80%” or “90%”. This occurs due to the operating conditions such as ambient temperature. In this case, “Charge” will be displayed properly, if UPS is operated normally for 1 or 2 hours.
- (3) Connect the battery connector correctly. If the UPS is operated without the batteries, “Charge” might show a value lower than the actual charge rate. Moreover, even if the battery connector is reconnected and operates the UPS, the proper charge rate is not displayed immediately. In this case, “Charge” will be displayed properly, if UPS is operated normally for 12 hours or more.
- (4) Display of “Charge” is only an approximation. An actual charge rate of the battery might differ slightly.

“Backup time” of Battery

- (1) In “Setting the shutdown trigger conditions” of SANUPS SOFTWARE STANDALONE, if “When the backup-time is under the specified value.” is selected as the shutdown trigger conditions, set the time more than 40% of the backup time displayed on the main screen. Refer to §6.4 “Setting the Shutdown Conditions” in the User Guide of SANUPS SOFTWARE STANDALONE for details.
- (2) If the “Load” displayed on the main screen is less than 30%, the backup time sometimes shows improper value.
- (3) “Backup time” displayed is only an approximation. An actual backup time might differ slightly.

§17. Using Standard OS UPS Services

You can use the standard UPS service of your operating system to execute an automatic shutdown when power is lost. See §17.1 or §17.2, depending on your operating system. Use the supplied Network cable to connect the PC I/F connector on the UPS to the serial connector on the computer.

Set the interface setting to “Standalone” to use the standard OS UPS service.

For details on the setting procedure, see §3.4 “Setting PC Interface” in the *User Settings Guide*.

§17.1 Windows NT

To make UPS settings, log in as a user with Administrator privileges.

- ① Select the UPS icon in the Control Panel, and set the check boxes as shown in the following figure.

No.	Item	Description
A	Uninterruptible Power Supply is installed on	Specifies the number of the COM port where you connected the UPS and the Network cable.
B	Power failure signal	Specifies that a warning message should be displayed according to the settings in the “UPS Service” section.
C	Low battery signal	Specifies that the OS shutdown should begin on reception of a UPS low battery signal. When this check box is not checked, the shutdown begins on reception of a power failure signal, according to the settings in the “UPS Characteristics” section.
D	Remote UPS Shutdown	When this check box is checked, the UPS shuts down 2 minutes after commencement of the OS shutdown. A Registry setting change is required to change the shutdown time.
E	Execute Command File	Check this check box and enter a command file name if you want to execute a command file before starting the shutdown. Only commands which finish executing within 30 seconds can be entered here.
F	Time between power failure and initial warning message	Specifies the time between a power failure and the initial warning message. No warning message appears if power is restored within the specified time.
G	Delay between warning messages	Specifies the interval between warning messages.
H	Expected Battery Life	This is enabled when “Low battery signal” is disabled.
I	Battery recharge time per minute of run time	This is enabled when “Low battery signal” is disabled. The recharge time is calculated as a sum from the time that the UPS service starts. Battery operation starts when power is interrupted, and the OS shutdown begins when the remaining backup time reaches 2 minutes.

- ② Click “Yes” in the message that appears when you click “OK”.

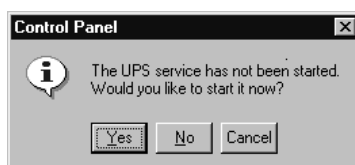

This completes the settings.

§17.2 Windows 2000/XP/Server 2003

To make UPS settings, log in as a user with Administrator privileges.

- ① Select the “Power Option Properties” icon in the Control Panel, and then click the “Select...” button in the UPS tab.

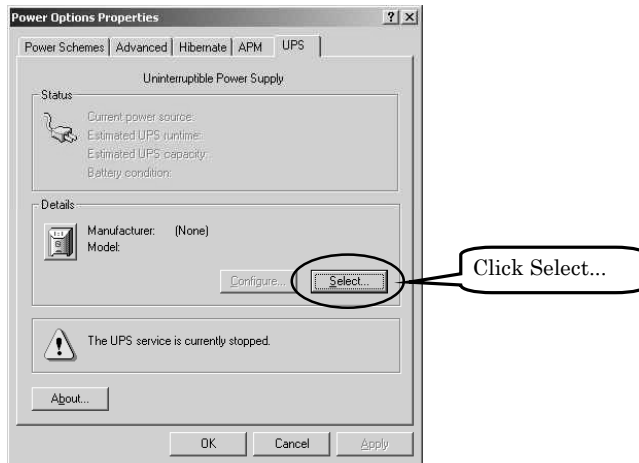

- ② Select “Generic” in the “Select manufacturer” list, select “Custom” in the “Select model” list, and then click “Next”.

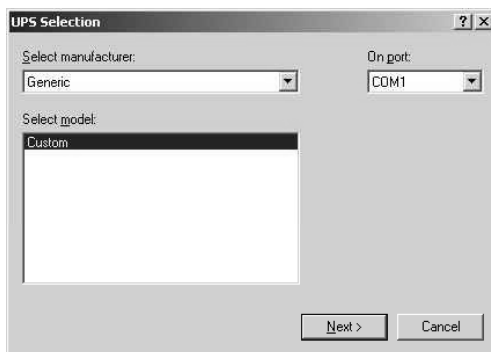

- ③ Make the settings shown in the following figure, and then click “Finish”.
(Select the “Positive” option before clearing the check from the UPS Shutdown check box.)

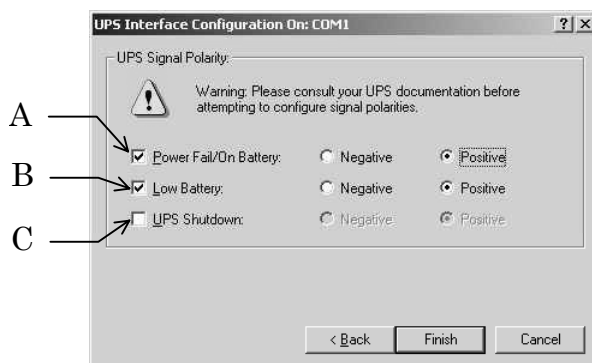

Note

Even if you enable “UPS Shutdown”, the UPS will not shut down automatically after Windows 2000/XP/Server 2003 shutdown. If you need automatic UPS shutdown, use the optional power management software.

No.	Item	Description
A	Power Fail/On Battery	Specifies that a warning message should be displayed according to the settings in the “UPS Service” section.
B	Low Battery	Specifies that the OS shutdown should begin on reception of a UPS low battery signal.
C	UPS Shutdown	Clear this check box.

④ Click the “Configure...” button.

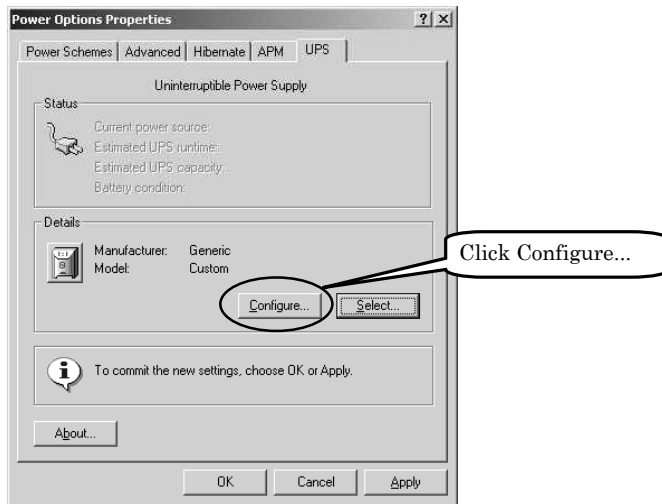

⑤ Make the settings shown in the following figure, and then click the “OK” button. When you return to the screen in step ①, click “Apply”.

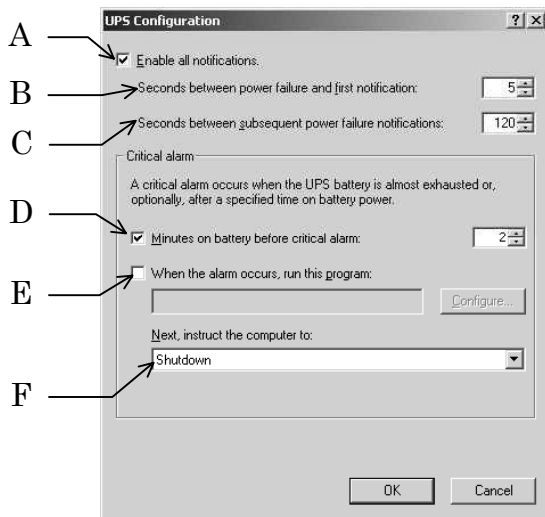

No.	Item	Description
A	Enable all notifications	Check this if you want to display all warning messages related to power failures.
B	Seconds between power failure and first notification	Specifies the time between a power failure and the first warning message. No warning message appears if power is restored within the specified time.
C	Seconds between subsequent power failure notifications	Specifies the interval between subsequent warning messages.
D	Minutes on battery before critical alarm	Specifies the number of minutes that should elapse after a power failure until the OS shutdown begins. The minimum time is 2 minutes. The OS shutdown begins after the specified time, or after the battery power becomes low (as specified in step ③), whichever occurs earlier.
E	When the alarm occurs, run this program	Check this check box and enter a command file name if you want to execute a command file before starting the shutdown. Only commands which finish executing within 30 seconds can be entered here.
F	Next, instruct the computer to	Specifies whether Windows 2000/XP/Server 2003 should shut down or hibernate. If you select “Shut Down”, Windows2000/XP/server2003 is shut down. “Hibernate” cannot be selected unless the “Enable hibernation” check box is checked in the “Hibernate” tab.

This completes the settings.

§18. Using Optional Equipment

This section explains the procedures for connecting and operating optional equipment. For more information about optional equipment, contact your supplier or a SANYO DENKI representative. Refer to the relevant sections of this manual or to the documentation of the optional equipment for information about wiring, settings, and operating procedures.

 CAUTION	<p>Connect optional equipment to the external interfaces of the UPS, before connecting the UPS input power plug to the utility power socket and after making sure that the UPS is completely stopped.</p> <p>If you need to connect optional equipment after operating the UPS, completely stop the UPS and connected loads, and disconnect their input power plugs from utility power sockets. Failure to do so can result in electric shock.</p>
---	--

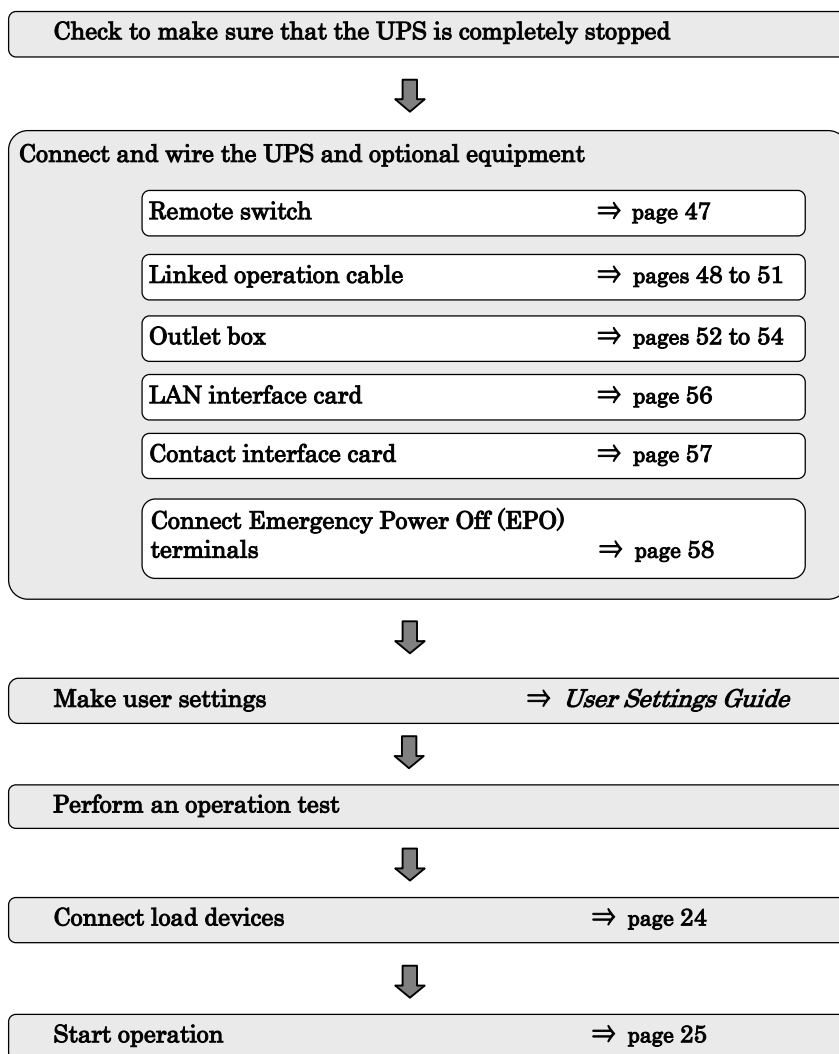

Note about using optional equipment

When you connect optional equipment, always check that it operates properly before using it in actual operation of the load devices.

§18.1 Remote Switch

This is a switch for turning the UPS ON and OFF from a remote location, and for executing one-touch shutdown* of connected computers.

* What is one-touch shutdown?

This is a function for sending a command requesting computer shutdown from the UPS to the power management software.

Equipment you will need

Remote switch (1)

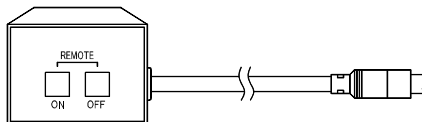

To control 1 UPS remotely

- ① Check that **MAIN SW** on the back panel of the UPS is set to “OFF”, and that the input power plug is not connected to the utility power outlet.
- ② Connect the remote switch to one of the REMOTE connectors.

CAUTION Before wiring, set **MAIN SW** on the back panel of the UPS to “OFF”, disconnect the input power plug from the utility power outlet, and make sure the UPS is completely stopped. Failure to do so can result in electric shock.

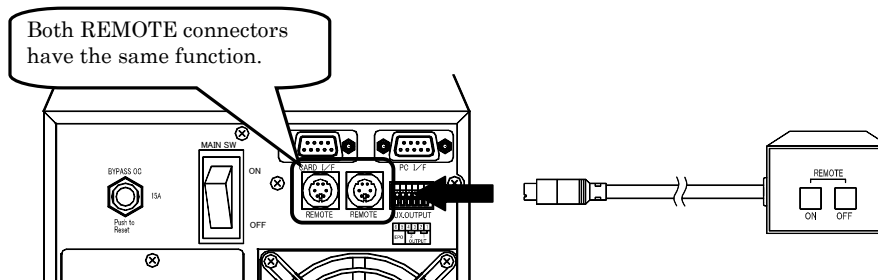

- ③ Connect the UPS input power plug to the utility power outlet, and set **MAIN SW** on the back panel to “ON”.
- ④ Set the Interface item in the user setting menu.

The following two functions are available, depending on the Interface setting. Select the setting for the function you want to use. See §3.4 “Setting PC Interface” in the *User Settings Guide* for details on the setting procedure.

1. To perform UPS remote ON/OFF
 - Set the Interface to **Standalone**.
2. To perform UPS remote ON and one-touch system shutdown
 - Set the Interface to **Workstation**.

Note about operating the remote switch

Always hold the remote switch ON/OFF switch down for at least 2 seconds.

To control multiple UPS units remotely

You can connect up to 5 UPS units with linked operation cables and control them remotely from a remote switch. This is called linked operation. For details, see §18.2 “Linked Operation Cable”.

§18.2 Linked Operation Cable

What is linked operation?

You can link up to 5 UPS units with cables and set their ON/OFF delay times, so that you can start and stop them in sequence. This is called linked operation. For linked operation, you will need linked operation cables and a remote switch.

Connect up to 5 UPS units with linked operation cables, and connect one of the UPS units to a remote switch. By turning the remote switch ON and OFF, you can turn the power ON and OFF for all load systems connected to the UPS units in one operation. You can also set the ON/OFF times for each UPS separately, allowing you to start and stop them in sequence.

The following figure shows the configuration of a linked operation system with 3 UPS units.

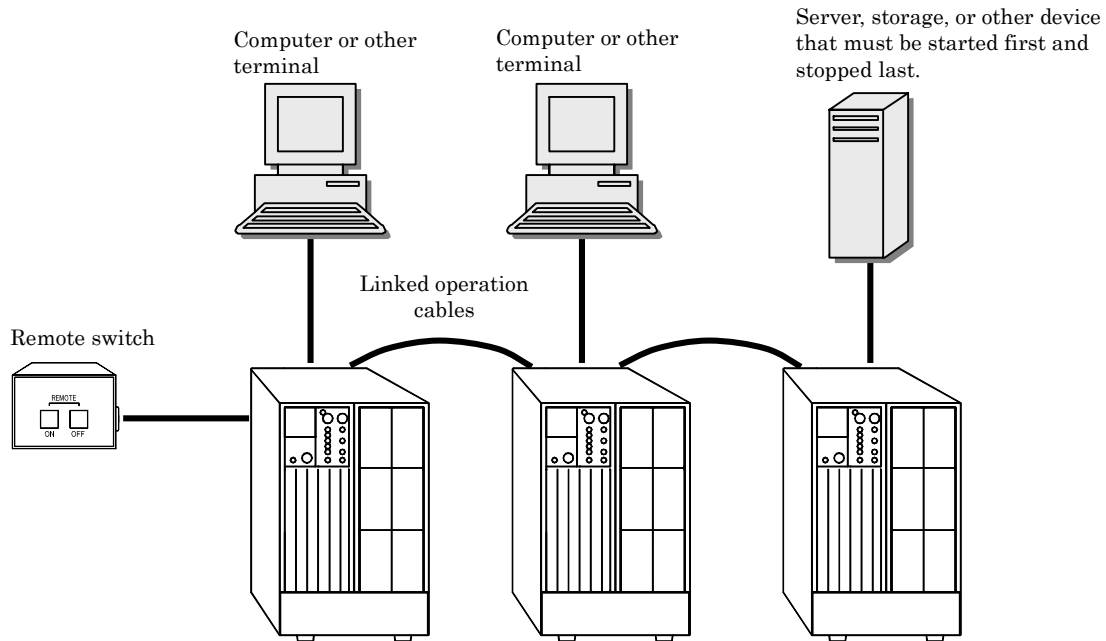

Configuration of linked operation system with 3 UPS units

Equipment you will need

Remote switch (1)

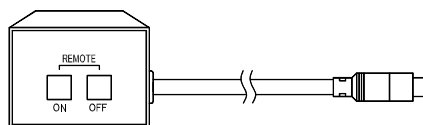

Linked operation cables

One cable fewer than the number of linked UPS units

(Example: 4 cables for a system with 5 linked UPS units)

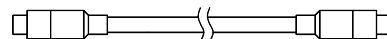

§18.2.1 Wiring and Settings for Linked Operation



Before wiring, set **MAIN SW** on the back panel of each UPS to “OFF”, disconnect their input power plugs from the utility power outlets, and make sure that each UPS is completely stopped. Failure to do so can result in electric shock.

- ① Set **MAIN SW** on all of the UPS units to “OFF”, and check to make sure that their input power plugs are not connected to utility power outlets.
- ② Connect the remote switch to one of the REMOTE connectors on UPS No. 1.
- ③ Connect a linked operation cable to the other REMOTE connector.
- ④ Connect this linked operation cable to one of the REMOTE connectors on UPS No. 2.
- ⑤ Continue in the same way to connect all UPS units with linked operation cables.

The following figure shows connections for a system with 3 linked UPS units.

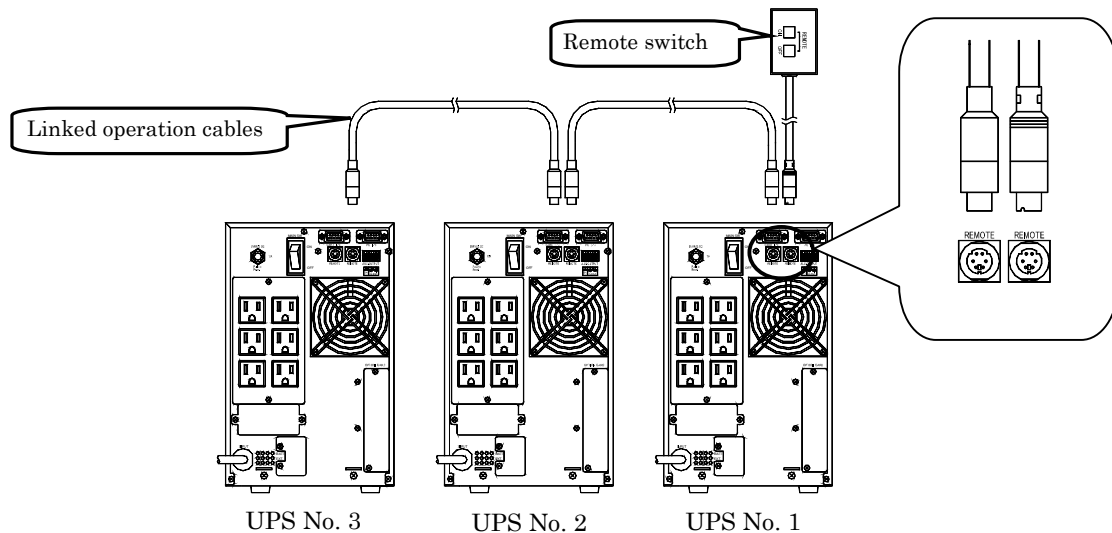

- ⑥ Connect the input power plugs of all UPS units to utility power outlets, and then set **MAIN SW** on the back panels to “ON”.
- ⑦ Set the Interface item in the user setting menu, according to the procedure in §3.4 “Setting PC Interface” in the *User Settings Guide*.

The following two functions are available, depending on the Interface setting. Select the setting for the function you want to use. Set the Interface setting for all connected UPS units. See §3.4 “Setting PC Interface” in the *User Settings Guide* for details on the setting procedure.

1. To perform UPS remote ON/OFF
 - Set the Interface to **Standalone**.
 2. To perform UPS remote ON and one-touch system shutdown
 - Set the Interface to **Workstation**.
- ⑧ Set user setting menu item §3.16 “Enabling and Disabling Linked Operation Delay” to “Delay”. See the *User Settings Guide* for details on the setting procedure.
 - ⑨ Set user setting menu items §3.17 “Setting Linked Operation ON Delay Times” and §3.18 “Setting Linked Operation OFF Delay Times” on each of the 3 UPS units. See the *User Settings Guide* for details on the setting procedure.

Tip

The above user settings are not required if you want to turn UPS output ON and OFF at the same time for all UPS units. Set item §3.16 “Enabling and Disabling Linked delay operation” to “No delay”

§18.2.2 Linked Operation ON Procedure

Note about linked operation

Linked operation starts or stops on an ON/OFF operation on the remote switch.
It does not start or stop on an ON/OFF operation with the  switch on the front panel.

- ① Check to be sure that all LEDs on all UPS units are off.

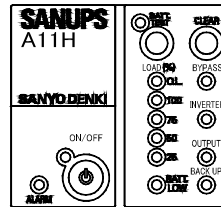

All of the LEDs are off.

- ② Press the “ON” button on the remote switch and hold it down for at least 2 seconds.

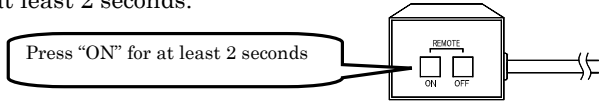

Note
Be sure to keep the remote switch button pressed for at least 2 seconds.

The UPS units start the linked operation ON sequence. After the specified time the system enters the operating state.

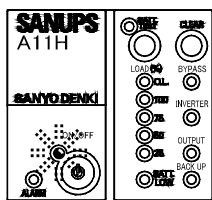

LEDs
Green ON/OFF Blinking

The “Green ON/OFF” blinks during the linked operation ON delay sequence.

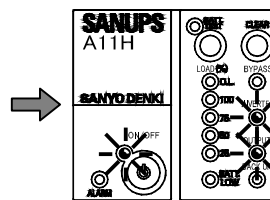

LED	
Green ON/OFF	Lit
Green OUTPUT	Lit
Green INVERTER	Lit

The “Green ON/OFF” lights when the system enters the operating state. The state of the other LEDs varies depending on load capacity and UPS operating status.

§18.2.3 Linked Operation OFF Procedure

- ① Check that “Green OUTPUT” lit for all UPS units.

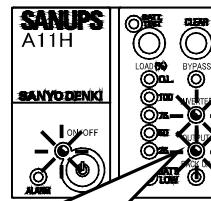

LED	
Green ON/OFF	Lit
Green OUTPUT	Lit
Green INVERTER	Lit

The state of the other LEDs varies depending on load capacity and UPS operating status.

Check that “Green OUTPUT” lit

- ② Press the “OFF” button on the remote switch and hold it down for at least 2 seconds.

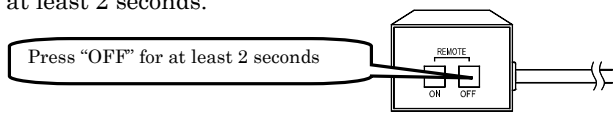

Note
Be sure to keep the remote switch button pressed for at least 2 seconds.

The UPS units start the linked operation OFF delay sequence, and stop after the specified time.
“Green ON/OFF” blinks during the linked operation OFF delay sequence.

§18.2.4 Linked Operation System Configuration

The following figure shows linked operation for the case when ON delay and OFF delay times have been set for 3 UPS units.

Remote switch ON/OFF operations control UPS output as shown below.

Note that UPS operation in response to a remote switch OFF operation differs according to the Interface setting.

Operation when Interface setting is “Standalone”

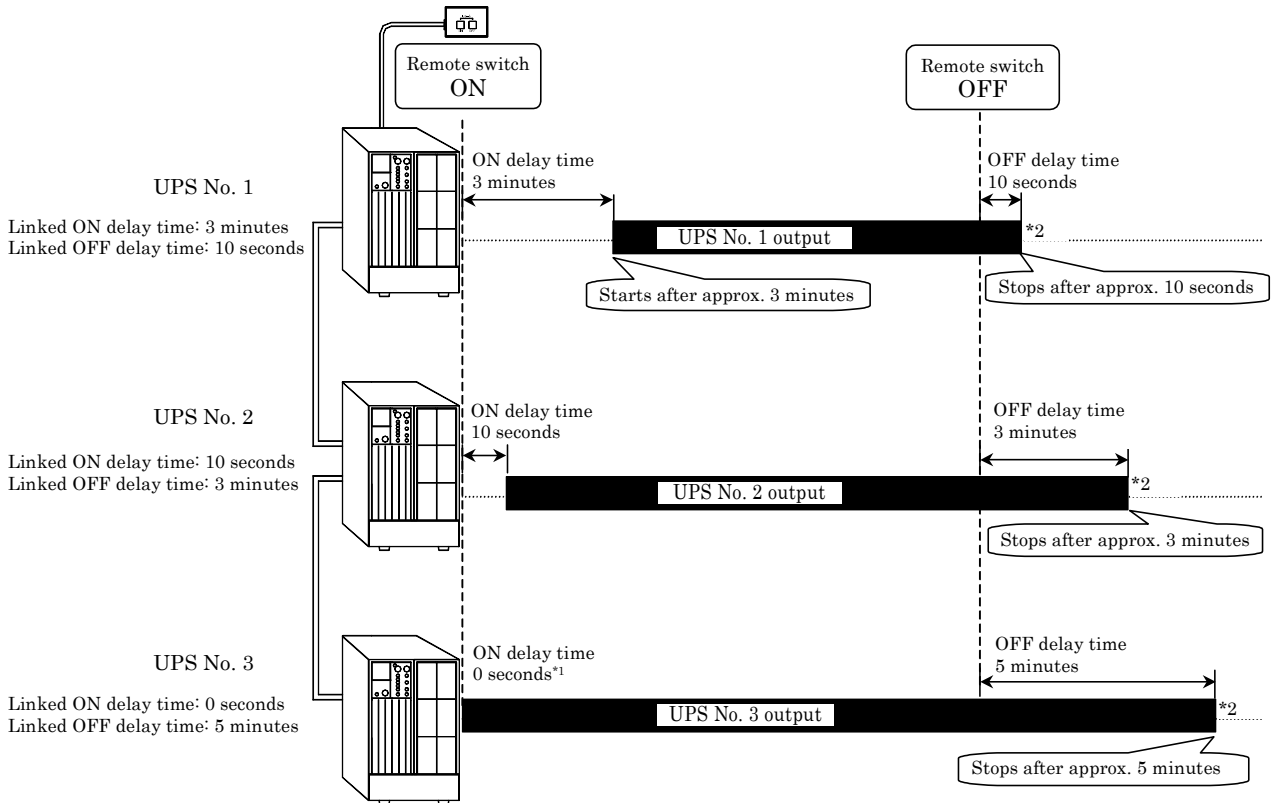

User settings for linked operation

*1: Even when the linked operation ON delay time is set to 0 seconds, several seconds are required before UPS output comes ON.

*2: You can use user setting §3.10 “UPS Operation at  OFF” in the *User Settings Guide* to select whether UPS power supply after the UPS stops is “OFF” or “Bypass”. When you select “Bypass”, UPS output after the UPS stops is bypass power supply.

However, the linked operation ON delay sequence starts at the point when UPS power supply changes from OFF to ON. Even if you perform an ON operation in this state (bypass), the UPS does not start the linked operation ON delay sequence. Instead, it switches from bypass power supply to inverter power supply. If you want the UPS to use the specified “ON delay time”, set §3.10 to “OFF”.

Operation when Interface setting is “Workstation”

If you set the Interface to “Workstation” in §3.4 “Setting PC Interface” in the *User Settings Guide*, a command requesting system shutdown is sent from the UPS to the power management software when you press the OFF button on the remote switch. The timing of the request is the OFF delay time specified in §3.18 “Setting the Linked Operation OFF Delay Time” in the *User Settings Guide* from the point when the OFF button was pressed.

The response of the UPS units to an ON operation on the remote switch is the same as when the Interface item is set to “Standalone”.

§18.3 Outlet Box

Use an outlet box if you want to control of the output from the UPS.

What is output line control?

Connecting an outlet box to the UPS provides three output lines: OUTPUT0, 1, and 2. You can set ON/OFF delay times for OUTPUT1 and 2, allowing you to control output start and stop. Operation that utilizes of this function is called **“Output line control”**.

When an outlet box is connected, the UPS output consists of the two lines OUTPUT1 and OUTPUT2, which can be controlled by output line control, and OUTPUT0, which is direct output from the UPS.

The user settings menu allows you to set separate ON/OFF delay times for OUTPUT1 and OUTPUT2. This makes it possible to start and stop connected load devices in sequence.

As an example of a system configured for power control, the following figure shows a computer and peripheral devices connected as loads to an outlet box.

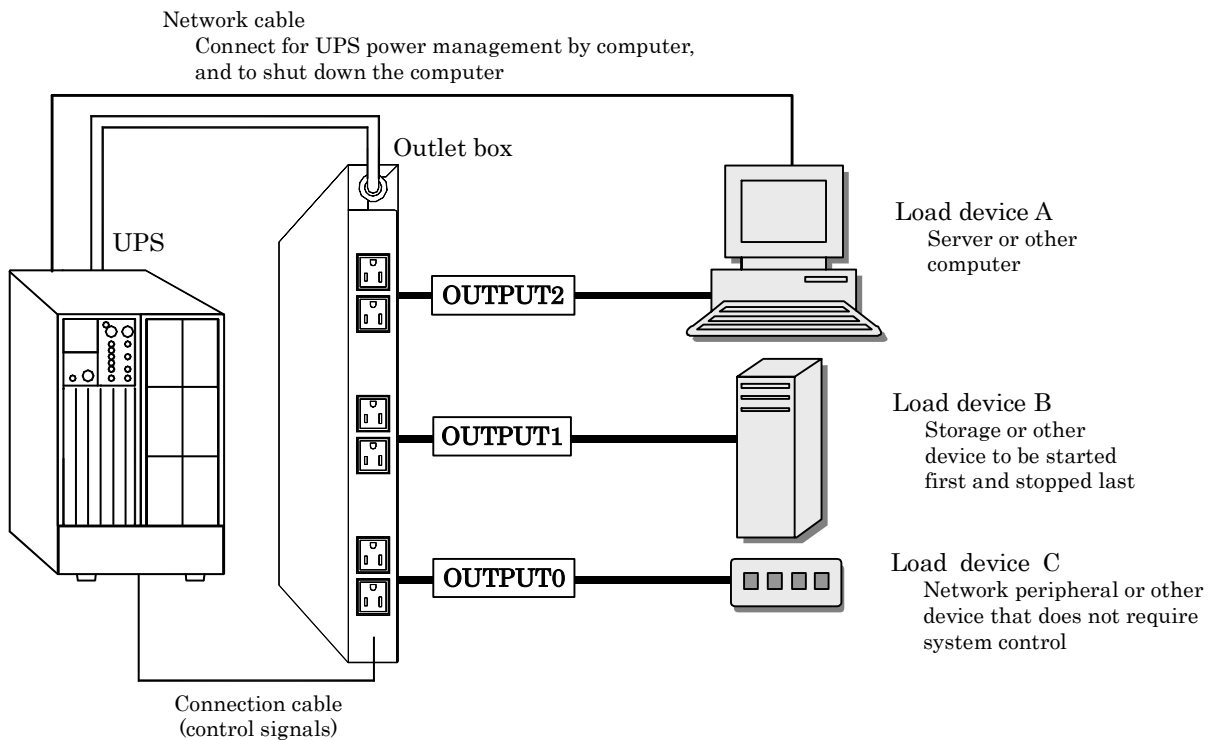

System configuration using outlet box

About connected load devices

Ensure that the total capacity of all load devices connected to the system control box **does not exceed 1kVA (0.7 kW)**. For details, see §10. “Load Devices Connection”.

§18.3.1 Outlet Box Wiring and Settings

Equipment you will need

Outlet box

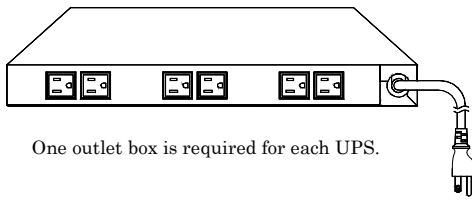

Connection cable
(supplied with outlet box)

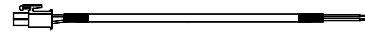

Before wiring, set **MAIN SW** on the back panel of the UPS to “OFF”, disconnect the input power plug from the utility power outlet, and make sure the UPS is completely stopped. Failure to do so can result in electric shock.

- ① Check that **MAIN SW** on the back panel of the UPS is set to “OFF”, and that the input power plug is not connected to the utility power outlet.
- ② Using the outlet box connection cable, connect the outlet box to the “AUX.OUTPUT” terminals 1 to 4 of the UPS.

AUX.OUTPUT terminal connection procedure

1. Depress the lever with a flat-blade screwdriver or similar tool, and then insert the wire into the terminal.
2. Pull the inserted wire to make sure it does not come out.

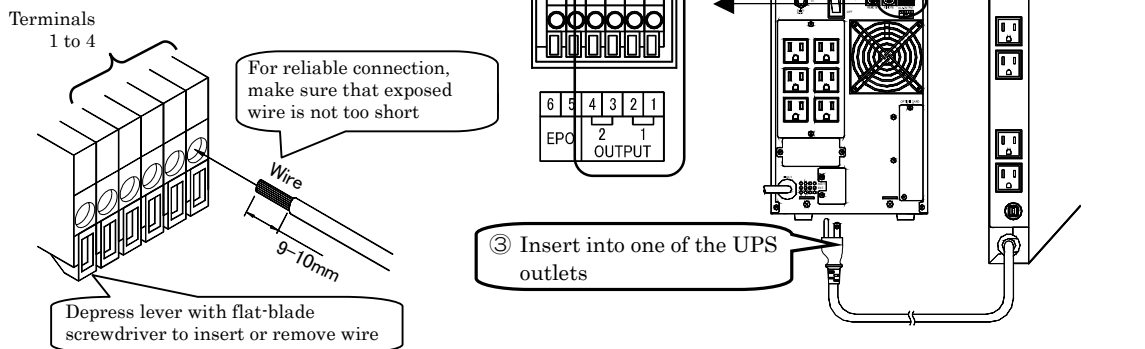

- ③ Insert the input plug of the outlet box into one of the UPS outlets.
- ④ Connect the input power plug of the UPS to a utility power outlet, and set **MAIN SW** on the back panel to “ON”.
- ⑤ Set item §3.19 “Enabling and Disabling Output line Control” in the *User Settings Guide* to “Enabled”.
- ⑥ Set the Output line Control items §3.20 to §3.26 in the *User Settings Guide*.
- ⑦ Set **MAIN SW** to “OFF”, check that the UPS is completely stopped, and then set **MAIN SW** to “ON” again to restart the UPS.

The setting of §3.19 “Enabling and Disabling Output line Control” in the *User Settings Guide* is enabled when the UPS restarts.

User settings when using an outlet box

Output line control with the outlet box does not function unless user settings menu item §3.19 “Enabling and Disabling Output line Control” is set to “Enabled”. **When using the outlet box be sure to set it to “Enabled”.** (The factory default setting is “Disabled”).

§18.3.2 Configuration of an Output line Control System

When the ON/OFF delay settings of OUTPUT1 and OUTPUT2 are set as shown in the following table, and you turn the UPS ON and OFF, power is supplied as shown in the following figure.

Example ON/OFF delay time settings for OUTPUT1 and OUTPUT2

Outlet	ON delay time	OFF delay time
OUTPUT1	10 seconds	3 minutes
OUTPUT2	3 minutes	10 seconds

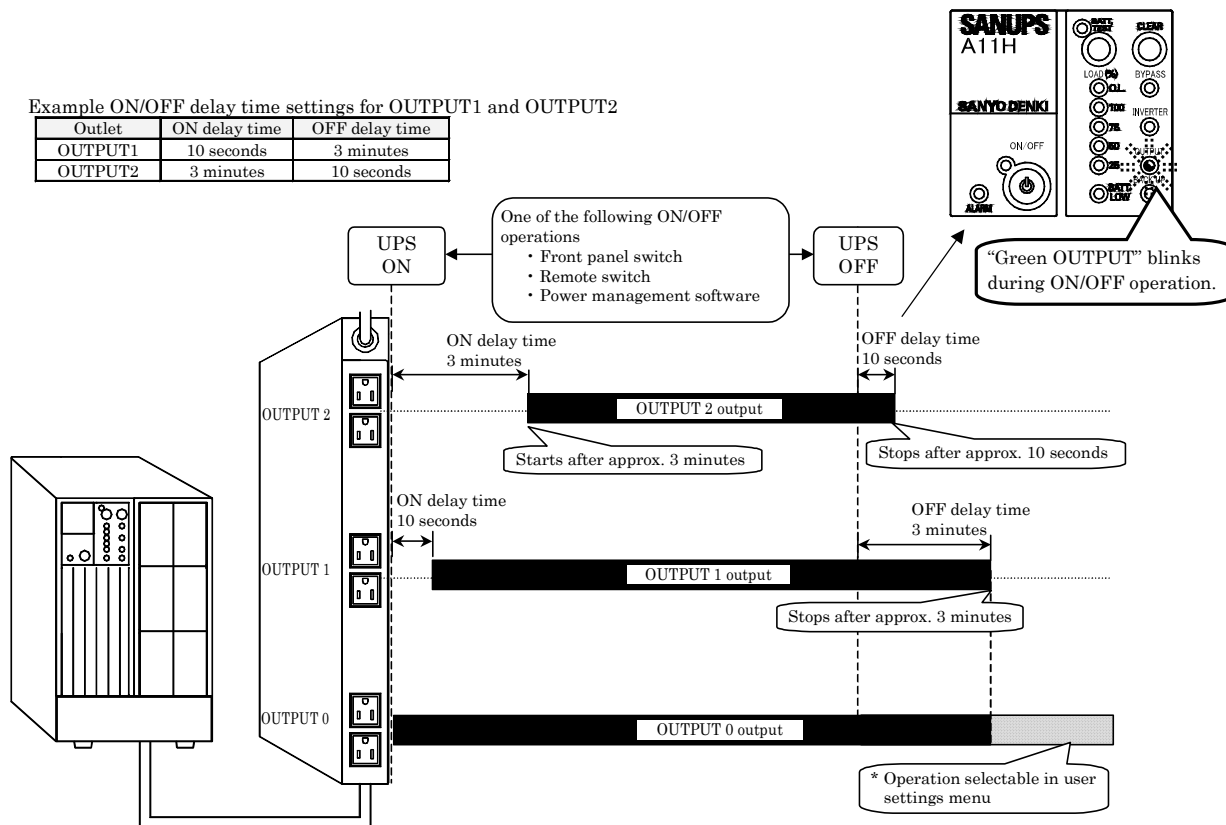

Output states of OUTPUT0, 1, and 2 under Output Line control

Operation of OUTPUT0 after OUTPUT1 and 2 stop

You can use the user settings menu to select the operation of OUTPUT0 after OUTPUT1 and OUTPUT2 stop for one of the following reasons ① to ③.

- ① Control by power management software
- ② Stopped by standard UPS service of the operating system
- ③ When the Interface item is set to Standalone, and power outage backup power is being supplied, after the passage of the outlet box power outage output times specified for OUTPUT1 and OUTPUT2 with items §3.24 and §3.25 in the *User Settings Guide*.

Depending on the setting of §3.26 in the *User Settings Guide*, the operation of OUTPUT0 is as shown in the following table.

User settings menu		OUTPUT0 operation
§3.26 "Setting the Operation of Outlet Box OUTPUT0 After Stopping of OUTPUT1 and 2"	Power supply stops (default setting)	OFF *
	Power supply continues	Bypass power supply

* Bypass power supply when the setting of §3.10 "Setting UPS Operation at  OFF" in the *User Settings Guide*.

When using optional "SANUPS SOFTWARE" power management software

- The optional "SANUPS SOFTWARE" power management software is required to connect two or more computers to OUTPUT1 and OUTPUT2, and perform independent shutdown and UPS power management. The "SANUPS SOFTWARE" allows the delay times of OUTPUT1 and OUTPUT2 to be set to user-specified values.
- When using an outlet box and the "SANUPS SOFTWARE" power management software, user setting menu items §3.20 to §3.26 in the *User Settings Guide* cannot be set on the UPS. Set in the power management software. For details, refer to the User Guide of the power management software.

§18.4 Combining a Remote Switch and Outlet Boxes

You can connect a remote switch, linked operation cables, and outlet boxes to operate multiple UPS units with linked operation and output line control. The following figure shows an example of linked operation combined with output line control in a system with 2 UPS units. When linked operation delay times and output line control delay times are set as in the following table, the UPS outputs start and stop in sequence, as shown in the figure. For details about the delay time setting procedure, see the items described in the *User Settings Guide*.

Example of ON/OFF delay time settings for linked operation and output line control

Delay time setting	Linked operation		OUTPUT1		OUTPUT2	
	ON delay	OFF delay	ON delay	OFF delay	ON delay	OFF delay
UPS1	10 seconds	10 seconds	—	—	—	—
UPS2	30 seconds	30 seconds	—	—	—	—
Outlet box 1	—	—	1 minute	1 minute	5 minutes 30 seconds	5 minutes 30 seconds
Outlet box 2	—	—	1 minute	1 minute	5 minutes 30 seconds	5 minutes 30 seconds

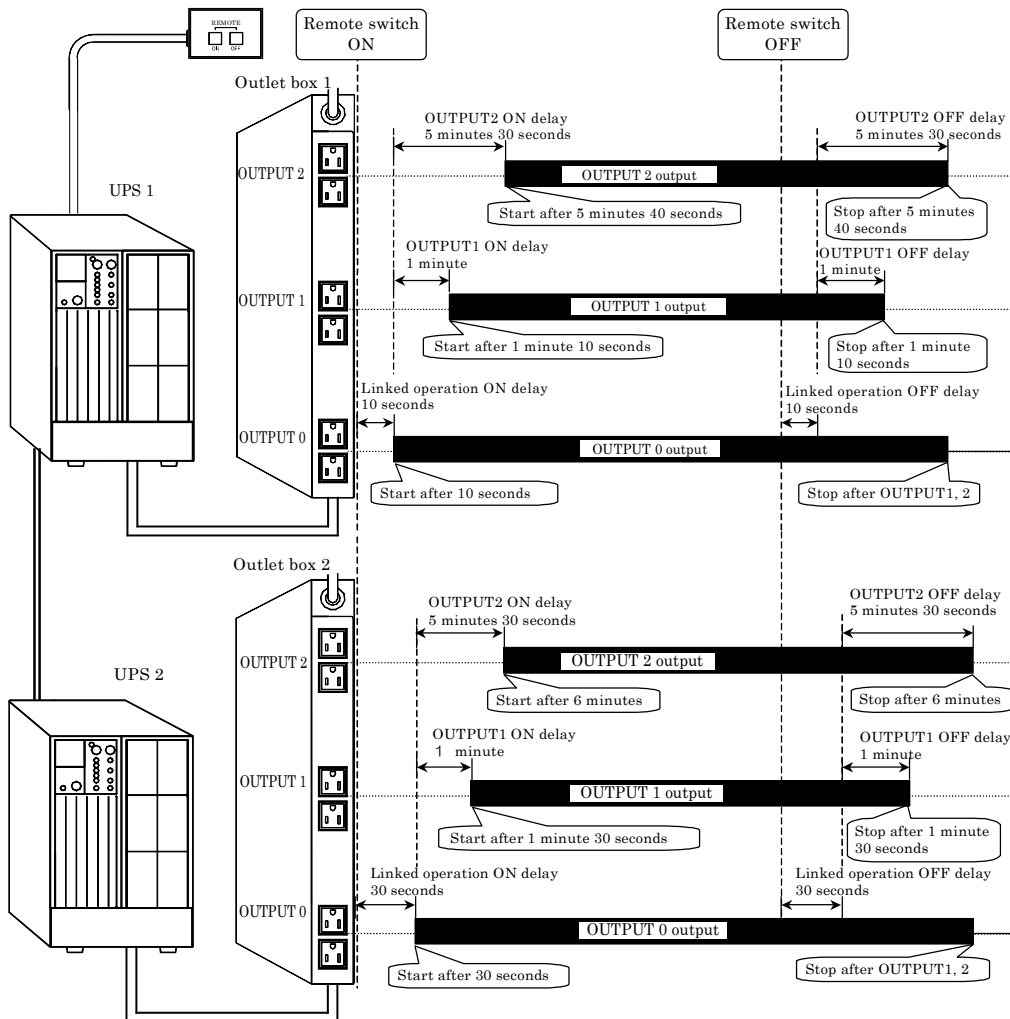

Operation when output line control is combined with linked operation

- When linked operation is combined with output line control, the operating order is as follows.
 1. Linked operation delay operation → 2. Output line control delay operation
- The actual delay time of the OUTPUT1 and 2 lines is the sum of the output line control delay time and the linked operation delay time.

$$\text{Actual line delay time} = \text{Linked operation ON/OFF delay time} + \text{Output line control delay time}$$

If linked operation ON delay time is not enabled under output line control

Depending on UPS user settings, OUTPUT0 power supply may continue when OUTPUT1 and 2 are OFF because of power management software control or another reason. In this state, when the ON button is pressed on a remote switch, linked operation ON delay time is disabled and OUTPUT1 and 2 are delayed only by the output line control delay time. To enable linked operation ON delay, make the following user settings so that OUTPUT0 also goes OFF when OUTPUT1 and 2 go OFF.

- ① Set §3.10 “Setting UPS Operation at  OFF” in the *User Settings Guide* to “OFF”.
- ② Set §3.26 “Setting the Operation of Outlet Box OUTPUT0 After Stopping of OUTPUT1 and 2” in the *User Settings Guide* to “Stop power supply”.

§18.5 LAN Interface Card

Use the LAN interface card to perform UPS power management and computer shutdown. When you use the LAN interface card, the optional “SANUPS SOFTWARE” is required. This software provides network support, and is separate from the power management software supplied on the CD-ROM. For detailed information about connections and settings, refer to the Instruction Manual of the LAN interface card and the SANUPS SOFTWARE.

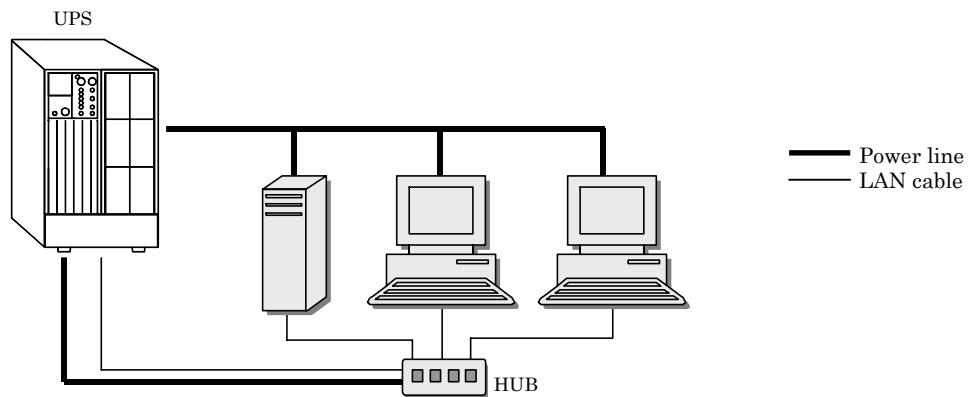

Network configuration for system using LAN interface card

Equipment you will need

LAN interface card

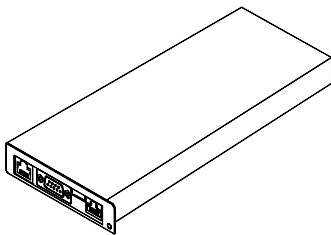

Communications cable for LAN interface card
(Supplied with LAN interface card)

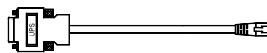

Power management software
SANUPS SOFTWARE

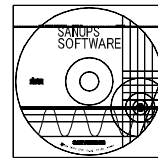

* One SANUPS SOFTWARE license is required for each computer that uses the software.

Connection procedure

- ① Insert the LAN interface card into the option card slot on the back panel of the UPS.
- ② Using the LAN interface card communications cable, connect the “CARD I/F” connector of the UPS to the “UPS” connector of the LAN interface card.

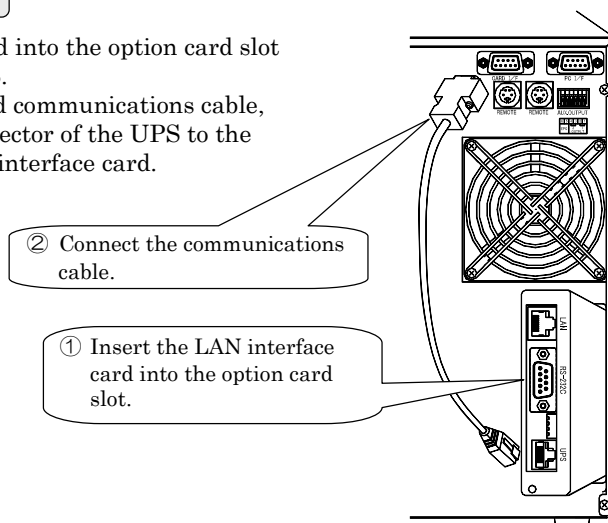

User settings

Set the Interface setting to “Workstation” (default setting). For details on the setting procedure, see §3.4 “Setting PC Interface” in the *User Settings Guide*.

Note

The contact interface card and LAN interface card cannot be used simultaneously.

§18.6 Contact Interface Card

Connect the contact interface card when you want to use the external transmission signals (transistor output) of the UPS “CARD I/F” connector as no-voltage contact (relay contact) output.

For detailed information about connections and so on, refer to the documentation of the contact interface card.

Contact interface card output signals

The following signals are output.

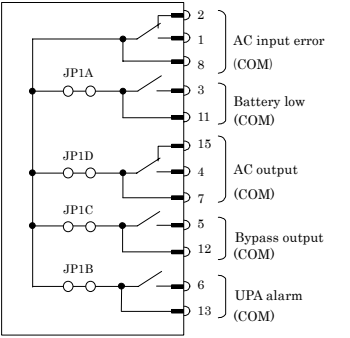

Signal name	Description
AC input error (COM)	This signal is output on a utility power outage or voltage error (a contact, b contact).
Battery low (COM)	This signal is output when the battery voltage drops below the specified level (a contact).
AC output (COM)	This signal is output when the UPS is supply AC power output to the load devices (a contact, b contact).
Bypass output (COM)	This signal is output when the UPS is supplying bypass power to load devices (a contact).
UPS alarm (COM)	This signal is output when a alarm condition occurs in the UPS main unit (a contact).

- All signals are output as no-voltage contact. Contact capacity is AC110V/DC24V 0.2A.
- Make short-pin settings for JP1A to JP1D according to the intended application of the contact signals. (When the unit is shipped from the factory, all short pins are inserted and set to common ground.)

Equipment you will need

Contact interface card

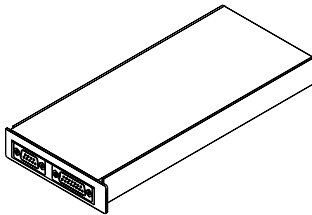

Communications cable for contact interface card

(Supplied with contact interface card)

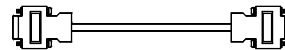

Connection procedure

- Insert the contact interface card into the option card slot on the back panel of the UPS.
- Using the contact interface card communications cable, connect the “CARD I/F” connector of the UPS to the “AUX IN” connector of the contact interface card.

② Connect the communications cable.

① Insert the contact interface card into the option card slot.

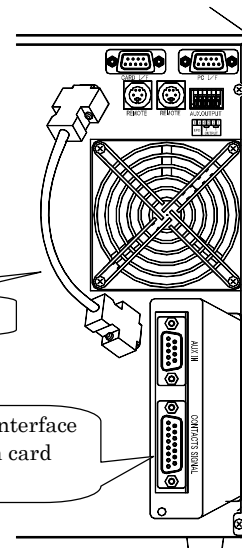

User settings

You can set the Interface setting to either “Workstation” or “Standalone”. The card operates under both settings.

Note

The contact interface card and LAN interface card cannot be used simultaneously.

§18.7 Connecting the Emergency Power Off (EPO) Terminals

To enable emergency stop of UPS output, connect the contacts of a switch or other required device to EPO terminals 5 and 6 of the AUX.OUTPUT block.

The switch to connect to the EPO terminals is not provided as a standard option for the UPS. Use a switch that complies with the following specifications, or connect to compliant contacts on your system.

For details about the functions of the EPO terminals, see “④ AUX.OUTPUT” in §5.3 “External Interfaces”.

EPO terminal specifications

- Circuit voltage: DC 5 V
- Current when shorted: Approx. 10 mA
- EPO operating conditions: Short-circuit terminals 5-6 for 0.2 seconds or longer
- EPO terminals: One-touch terminal block (compatible wires: AWG26 to 20)

AUX.OUTPUT terminal connection procedure

- ① Strip about 9 to 10mm of the sheath at the tip of the cable.
- ② While depressing the lever with a flat-blade screwdriver or similar tool, insert the wire into the terminal.
- ③ Pull the inserted wire to make sure it does not come out.

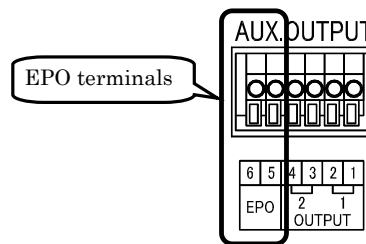
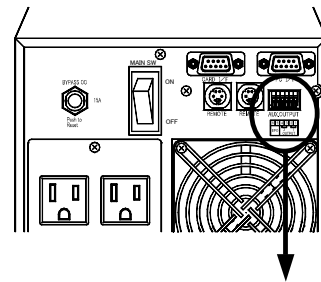
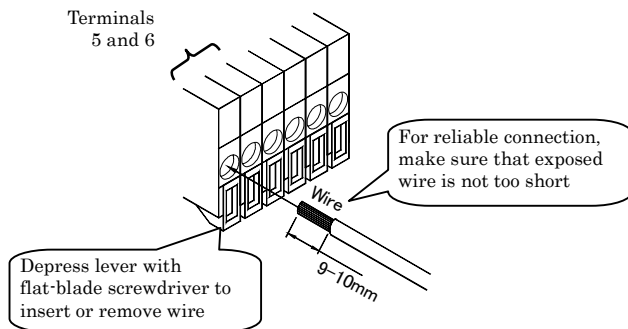

UPS emergency stop procedure

- ① Press the emergency power off switch.

An emergency stop of the UPS is executed, and all LEDs go off.

In this state, the UPS remains powered off even if you cancel the emergency power off on the emergency power off switch.

Note

User setting menu items cannot be changed during an emergency power off.

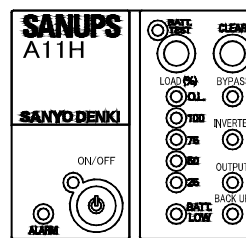

Buzzer
No sound
All of the LEDs go off.

UPS restart procedure

- ① Cancel the emergency power off on the connected switch
- ② Press  for at least 1 second on the UPS.

The emergency power off is cancelled, “Green OUTPUT” and “Green ON/OFF” light, and the UPS returns to normal operation.

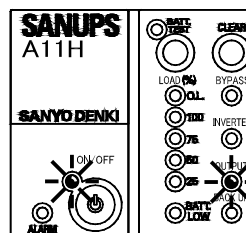

Buzzer
Musical trill
LEDs
Green ON/OFF Lit
Green OUTPUT Lit

§19. Characteristic of UPS

§19.1 Basic Operation

(1) Normal operation

The UPS converts AC power from the utility power source into DC power through the rectifier, and reconverts this DC power back into AC power through the inverter and supplies it to the load. The output power is stable AC power synchronized with the input power source. The batteries are kept continually charged and ready in case a problem (outage or voltage drop) occurs in the utility supply.

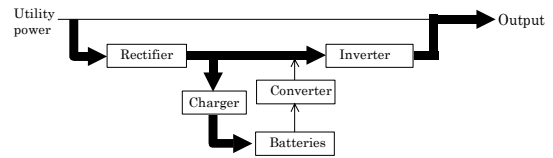

(2) On failure of utility power

When a fault or an outage occurs in the utility power source, the rectifier and charger cease operating while inverter operation continues, now using the batteries as a DC source to produce AC voltage, to ensure stable power supply to the load without even a momentary power dropout. At the same time, the buzzer sounds the battery operation alarm, and the “Orange BACK UP” indicator starts lighting.

(3) Upon recovery of utility power

When normal utility power is restored, rectifier and charger operations resume automatically, returning to the normal operating state described in §19.1 (1).

(4) When battery voltage declines

When low voltage or an outage in the utility power source continues, causing the battery voltage to decline to about 22 V (1.85 V/cell), the “Red BATT.LOW” indicator lights to indicate low battery voltage.

* When “Low Battery Voltage Warning Timing” in the user setting menu is set to “2 minutes” or “3 minutes”, the alarm is issued at the point when the remaining battery time drops to the specified level.

(5) Extended power outage

If a power outage persists and the battery voltage reaches the final discharge level, a protective circuit shuts off the inverter to prevent over-discharging of the batteries. When normal utility power recovers after the inverter has been stopped automatically, operation is automatically resumed, returning to the normal operating state described in §19.1 (1).

* When “UPS Operation Upon Power Recovery” in the user setting menu is set to “OFF”, inverter output remains stopped. When it is set to “30%”, “50%”, or “80%”, the UPS restarts operation once the batteries are charged to the specified level and then returns to the normal operating state described in §19.1 (1).

§19.2 Protective Functions

(1) Overload protection

If the UPS output is overloaded by exceeding the current capacity of the inverter, such as when a computer system boots up, the output selector automatically switches the source of AC power from the inverter to the bypass circuit, without interruption.

After a certain period of time has elapsed, the source of power to the load is switched back to the inverter without interruption (auto-return), as shown in §19.1(1).

* When “Overload Recovery Operation” in the user setting menu is set to “Bypass”, the UPS switches to inverter power supply without interruption when the overload is resolved.

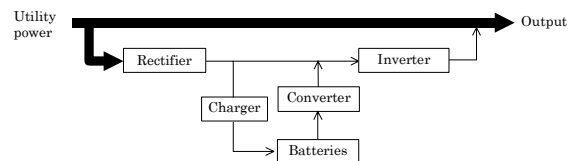



(2) UPS fault protection

If a fault occurs in the UPS, the output selector activates automatically and switches to bypass power without interruption. The “Red ALARM” indicator lights, and the alarm buzzer sounds. The power supply route is the same as for an overload.











































Output from the UPS will stop if a power outage occurs during bypass operation due to the UPS fault. Contact your supplier or SANYO DENKI as soon as possible.

§19.3 Protective Function Table

Indication of the marks in the table are as follows.

- Lit LED : 
- Blinking LED : 
- Buzzer Alarm : ① - ④

The following table shows functions and operations which activate to protect the UPS.

Item	Control panel (front panel) indicators								Alarms Buzzer (*1)	Protective functions (UPS operations)	Notes
	Orange BACK UP	Green OUTPUT	Green ON/OFF	Green INVERTER	Red BYPASS	Red ALARM	Red O.L	Red BATT. LOW			
Preparation	-	(*2)	(*2)	-	-	-	-	-	-	Rectifier, charger, operation	Power up
Normal	-				-	-	-	-	-	Inverter operation	Power up, operation
Serious failure	-			-			-	-	①	Stop inverter Bypass supply	
Overload (effective value)	-			-		-		-	④	Bypass supply	Auto return
Forced bypass	-			-		-	-	-	-		Manual switch to bypass supply
Input over voltage					-	-	-	-	②	Stop rectifier and charger Inverter operation	Battery operation
Input over voltage (prolonged)					-	-	-		③		Battery operation (*3)
Power outage					-	-	-	-	②		Battery operation
Power outage (prolonged)					-	-	-		③		Battery operation (*3)
Input error (frequency)					-	-	-	-	②		Battery operation
Input error (prolonged)					-	-	-		③		Battery operation (*3)
Battery failure	-	-	-	-	-		-		①	Stop inverter Bypass supply	

(*1): Buzzer sound patterns:

- ① * _____ Continuous tone
- ② ** ** Continuous beeps
- ③ ***** Continuous beeps
- ④ **** **** ...

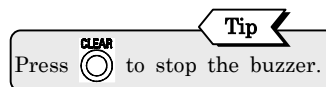

(*2): In this state, the LED blinks or is off, depending on the setting of “UPS Operation at  OFF” in the user setting menu.

- When this setting is set to “Bypass” 
- When this setting is set to “OFF” : -

(*3): Battery operation. Stops inverter operation when final battery discharge is reached.

§19.4 Specifications

Item		Standard or Performance	Notes	
Output capacity		1kVA/0.7 kW		
Cooling system		Forced air cooling		
AC input	Phases	Single phase, 2-wire		
	Voltage	55 to 150V	Raged Voltage : 120V (*6)	
	Frequency	40 Hz to 120 Hz	±1, 3, 5%: Sync Range	
	Power requirements	0.9 kVA	Max. capacity during battery charging	
	Input power factor	0.95 or more	During rated output (*2)	
	Phases	Single phase, 2-wire		
AC Output	Voltage	120 V		
	Voltage regulation	Rated voltage ±2%		
	Rated frequency	50 Hz or 60 Hz	User settable	
	Frequency regulation	Rated frequency within ±1, 3 or 5%:	1, 3, 5% selectable Free running ±0.5%	
	Voltage waveform	Sine wave		
	Distortion factor of voltage waveform	Linear load: 3% or less 100% rectifier load: 7% or less	During rated output	
	Transient voltage variation	Rapid load change	Rated voltage ±5%	0%↔100% at transient or output switch
		Power outage, recovery		During rated output
		Rapid input voltage change		±10% variation
	Response time	5 cycles or less		
	Load power factor (lag)	0.7 (lag)	Variation range 0.7 (lag) to 1.0	
	Overcurrent protection	Auto switch to bypass circuit at 105% or more		
	Overload capability	Inverter	105%	200 ms
		Bypass	200%	30 seconds
			800%	2 cycles
	Batteries	Type	Small sealed lead battery	
		Rated capacity	68 W	15 minute-rate
Number		2 (12V per battery)	2 in direct series	
Backup time		5 minutes (700 W) 10 minutes (500 W)	At 25°C (77°F) ambient temperature, rated load, with new battery	
Generated heat	125 W			
Input leakage current	3 mA or less			
Operating environment	Ambient temperature: 0 to 40°C (32 to 104°F) Relative humidity: 20 to 90%	(*3)		
Acoustic noise	40 dB or less	1 m (approx. 40 inches) from UPS front panel, 'A' characteristics (linear load)		

(*1): The inverter is capable of operation synchronized with AC input frequency and instantaneous switchover provided that the AC input frequency is within the rated frequency, and the AC input voltage is within the rated voltage.

(*2): When input voltage waveform distortion is under 1%.

(*3): The UPS contains batteries. Battery service life will be foreshortened if the UPS is used in an environment where the ambient temperature exceeds 30°C (86°F).

(*4): If grounded, the ground phase of the input and output must match according to UPS specifications.

(*5): The above table lists standard specifications. Some specifications are different for units with long backup times. For details, refer to the external battery specification instruction manual.

(*6): When AC input voltage is within 55V to 96V, the load capacity is derated from the rated capacity of the UPS.

§20. Warranty

Warranty for use in Japan: 1 year

Warranty for use Overseas: 1 year

Warranty for use in North America: 3 years*

* Valid only when the UPS is purchased from a vendor recognized by Sanyo Denki.

1. In the above areas, this product is warranted for the specified periods against electrical failures due to materials or workmanship.
2. Free repair or replacement by a product with equivalent functions will be made when it is determined that failure has occurred because of defects in materials or workmanship.
3. This warranty is void in the event of any modification or change to the product supplied by Sanyo Denki.
4. This warranty is void in the event of any improper use of the product supplied by Sanyo Denki, or failure to use the product as specified in this Instruction Manual.
5. This warranty does not apply when the product is used aboard a ship or in another area subject to vibrations.
6. This warranty does not apply when the product is operated under extraordinary conditions, for example periodic complete discharge of the batteries.
7. This warranty is void in the event that the product supplied by Sanyo Denki is installed in an inappropriate location.
8. This warranty does not apply to failures due to accidents, improper use, or use for other than the product's intended use.
9. This warranty does not apply to defects or damages arising from fire, earthquake, storm or flood disaster, lightning or other natural disasters including pollution, salt disaster, gas disaster (chloride gas), non-standard voltage or incorrect power sources other than those specified.
10. This warranty does not apply to defects or damages arising from mishandling, such as during transportation, relocation or dropping of the UPS by the customer after purchase.
11. Sanyo Denki reserves the right to determine whether damage to a load device connected to this product is due to faulty operation by this product. (In the event of any such claim, the affected load device must be sent to Sanyo Denki for inspection.)
12. Warranties for devices other than the product supplied by Sanyo Denki shall be the warranties provided by the manufacturers of those devices.
13. Sanyo Denki provides no warranty for products made by other manufacturers used or composed in the products manufactured by Sanyo Denki.
14. This warranty applies to the product specified by Sanyo Denki. It does not apply to any other device.
15. Sanyo Denki disclaims all responsibility for damage to load device software, loss of data, lost profits, and lost opportunities.
16. This warranty does not apply to medical or industrial devices connected to this product.